



i-ntelligent i-nnovative i-mpressive



"Minimally Invasive Swiss Implants"

CONTENT

i-system implants	2
Macro-micro design characteristics	4
Locking conical connection	5
Sloping shoulder	7
Square edged fins	8
Inter-fin distance	8
Anti-rotational channels	8
Incrementally deepening grooves	9
Biconical inner-outer body shape	9
Safe apex	9
i-mimetic surface	10
Short implant range	16
Prosthetic components	18
Surgical protocol	44
Surgical steps	46

i-system

IMPLANTS

i-system provides dental implants produced with Swiss precision and the latest technologies. i-system has a wide range of implant and prosthetic components, which provide solutions for all clinical indications.

The straightforward surgical technique and prosthetic approach eliminate the need for complex treatments, making isystem simple and minimally invasive.





Minimally invasive, maximally predictable.

MACRO-MICRO DESIGN

CHARACTERISTICS

i-system implants combine unique micro and macro design features, which provide case-specific outcomes with long term function and aesthetics.

The system delivers straightforward, clinically proven solutions, even in highly compromised solutions.



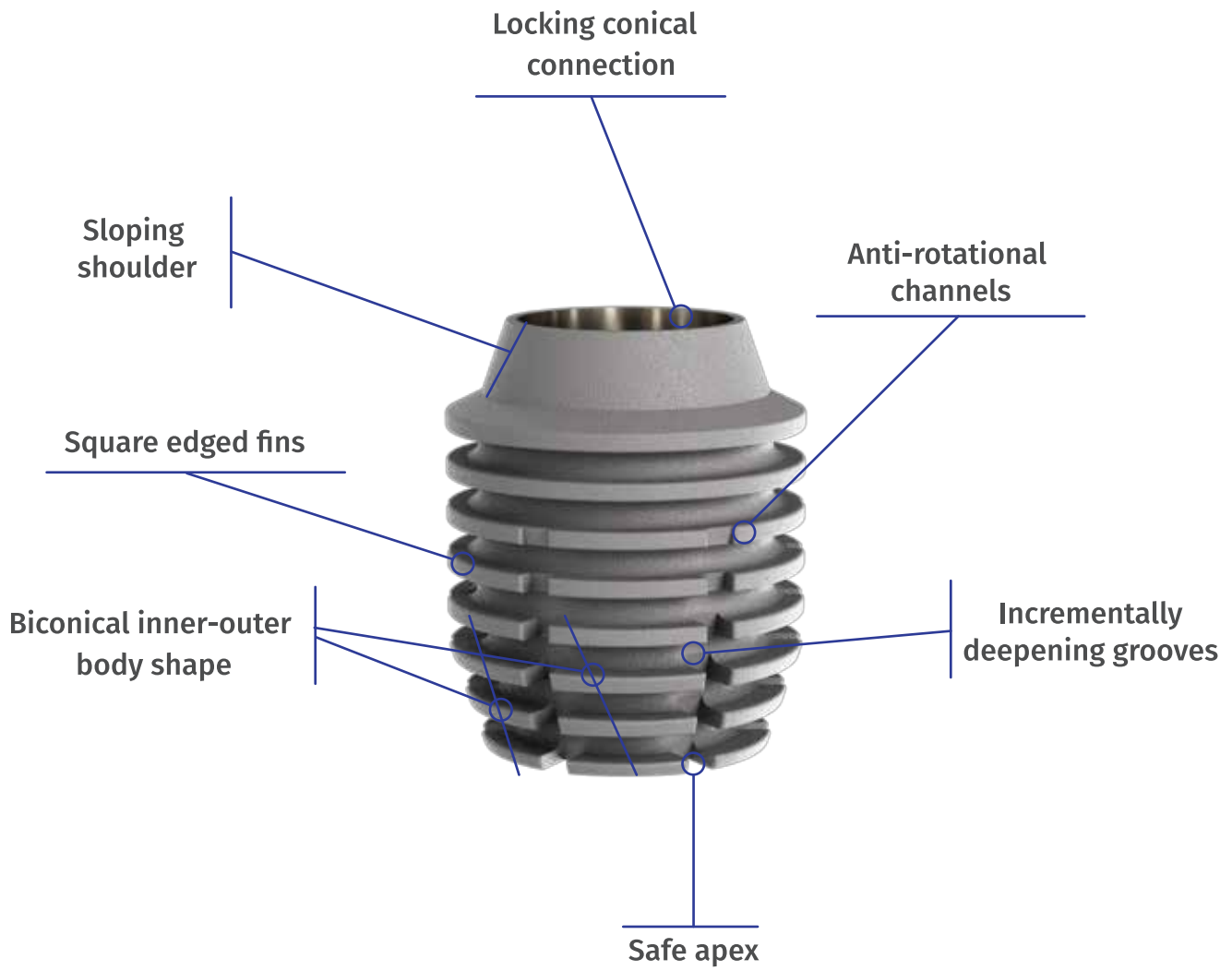

1.5° LOCKING CONICAL CONNECTION:

The extremely precise manufacturing process guarantees an accurate, precision fit of the abutment into the implant.

The 1.5° conical connection provides a perfect fit between the implant and the abutment. Therefore, micromovement and microleakage issues are eliminated.

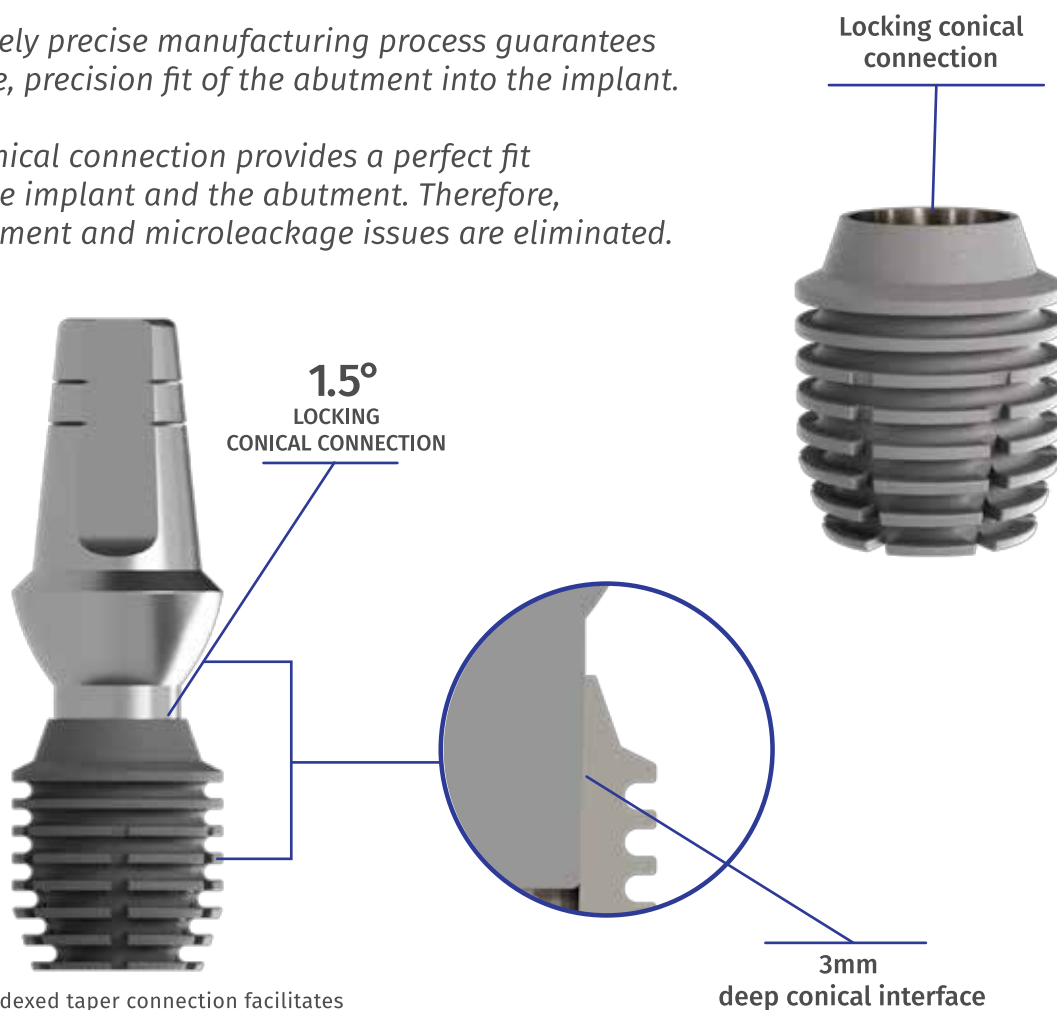

The non-indexed taper connection facilitates total restorative flexibility for dental professionals.

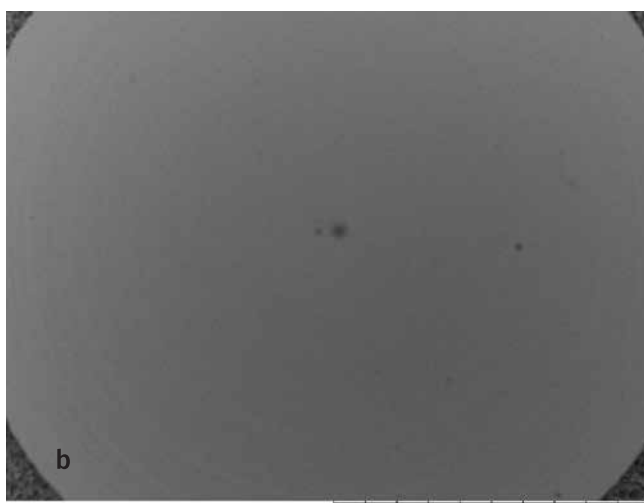
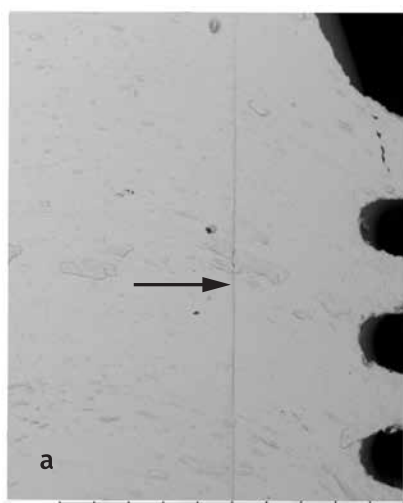

SEM images of implant-abutment interface a) Vertical b) Horizontal sections.

Gap < 10μ



SLOPING SHOULDER:

The sloping shoulder provides space for hard and soft tissues, even in cases with limited tissue volume.

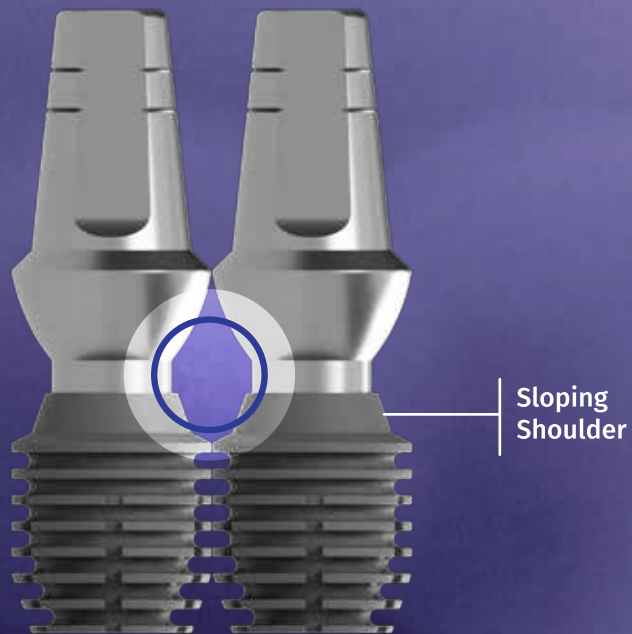

i-system



conventional implant

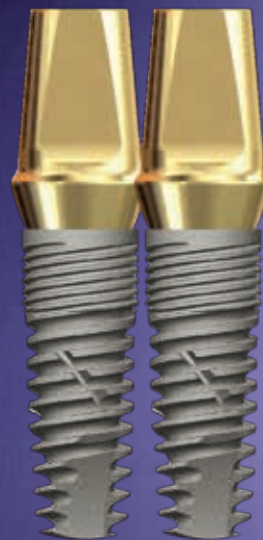

More space for soft tissues
More space for hard tissues
Safer to place close to an implant
Safer to place close to a tooth

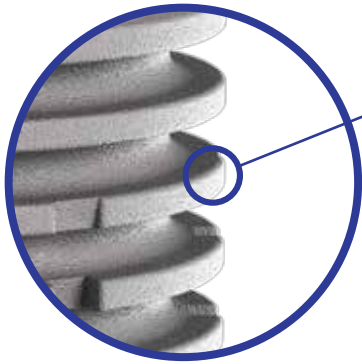

SQUARE EDGED FINS:

The shape of the fins provides optimum stress distribution to the alveolar bone. The square edges also offer significantly more bone-implant contact compared to other designs.

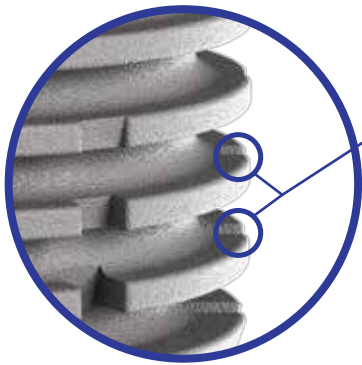

INTER-FIN DISTANCE:

Optimum inter-fin distance provides improved biomechanical stress distribution and provides a greater surface area for bone to implant contact than screw-type implants.

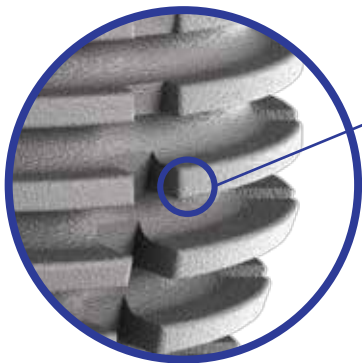

ANTI-ROTATIONAL CHANNELS:

Anti-rotational channels, together with the square-shaped fins, increase the resistance to rotational forces. The channels also allow for connective vascularity between the grooves, delivering improved healing and bone remodeling.



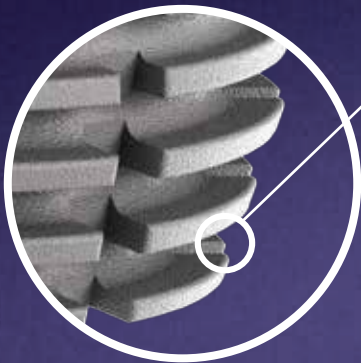

INCREMENTALLY DEEPENING GROOVES:

Enhance the surface area and effectively distribute the functional load.

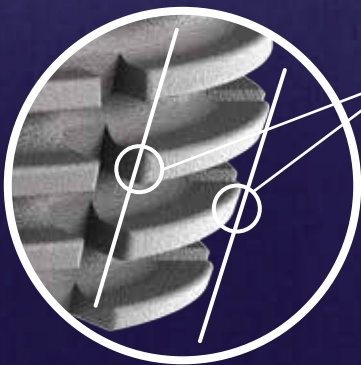

BICONICAL INNER-OUTER BODY SHAPE:

Biconical shape of the implant enhances the mechanical stability and stress distribution to surrounding hard tissues.



SAFE APEX:

Flat apex eliminates the risk of nerve damage and sinus membrane perforation during insertion.

i-mimetic

SURFACE

i-mimetic surface represents the ideal structure for optimal osseointegration, increased cell attachment and enhanced bone quality.

The surface characteristics of i-system ensures a perfect harmony between the micro and macro design of the implant.

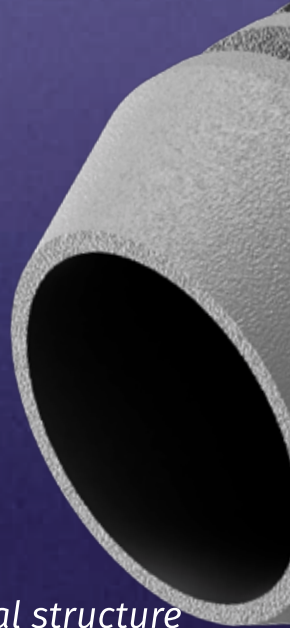

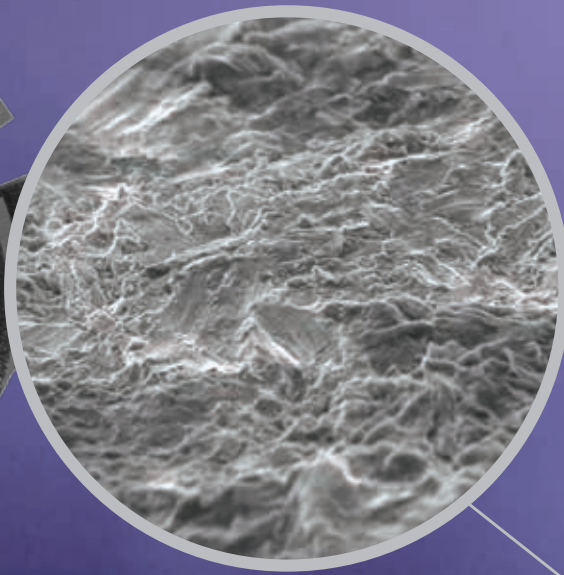
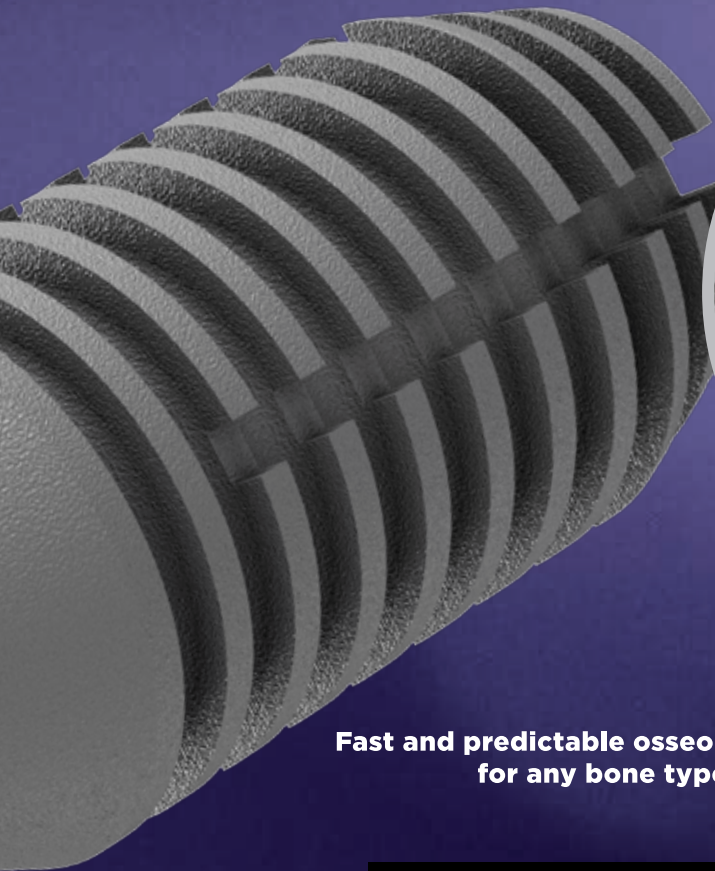

i-mimetic Surface

**Fast and predictable osseointegration
for any bone type.**

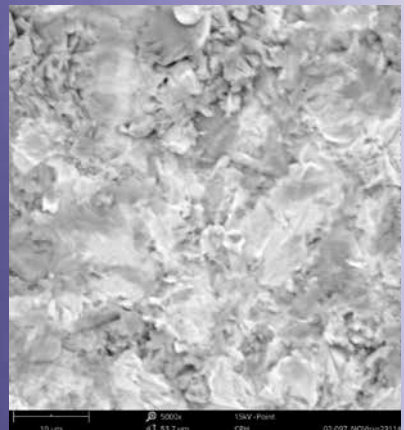
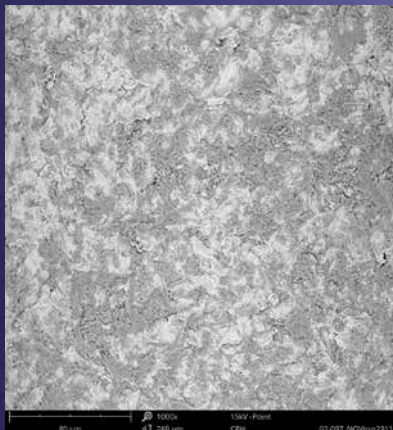
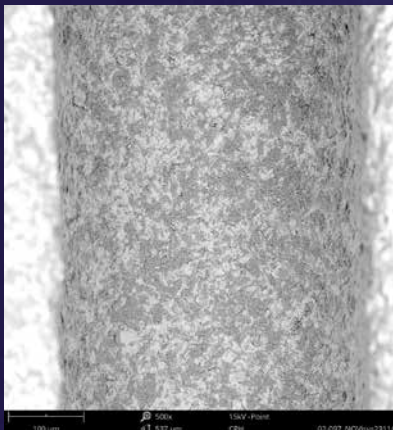
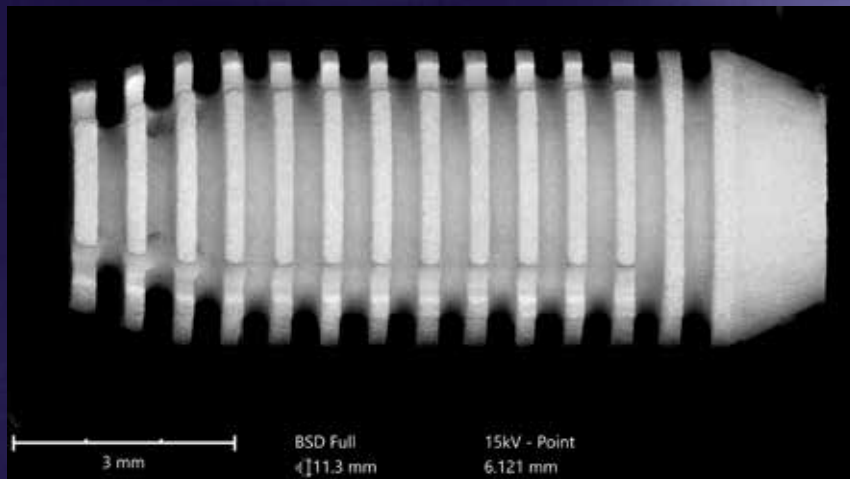



IMPLANT SYSTEM

i-system offers a wide range of implants and prosthetics to provide comprehensive solutions for all indications in implant dentistry.





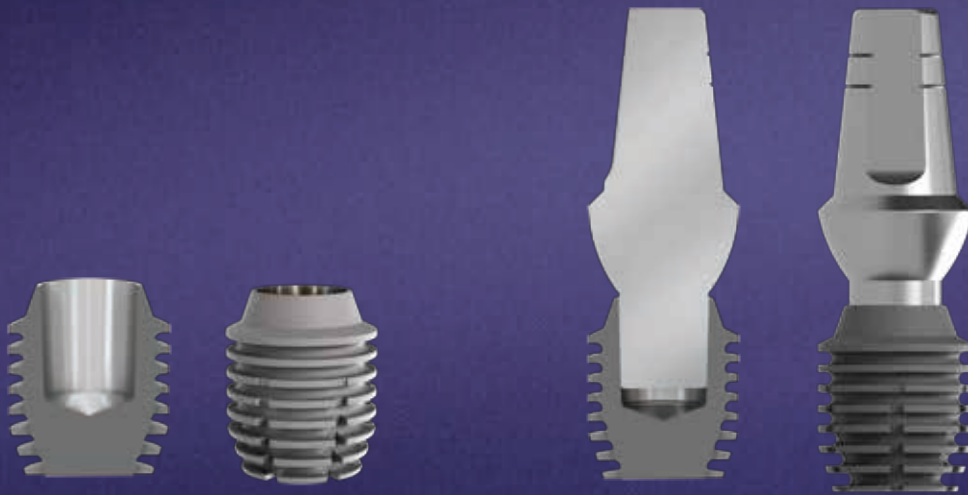

Width (W): The width of i-system implants are between 3.0-6.0mm.

Height (H): The height of i-system implants vary between 4-10mm depending on the width of the implant.

Well: The system includes implants with 2.0, 2.5 and 3.0mm wells depending on the width of the implant.

Material: All i-system implants are produced from highest quality titanium alloy (Ti-6Al-4V ELI, ASTM F136).



Implant Size Selection Chart

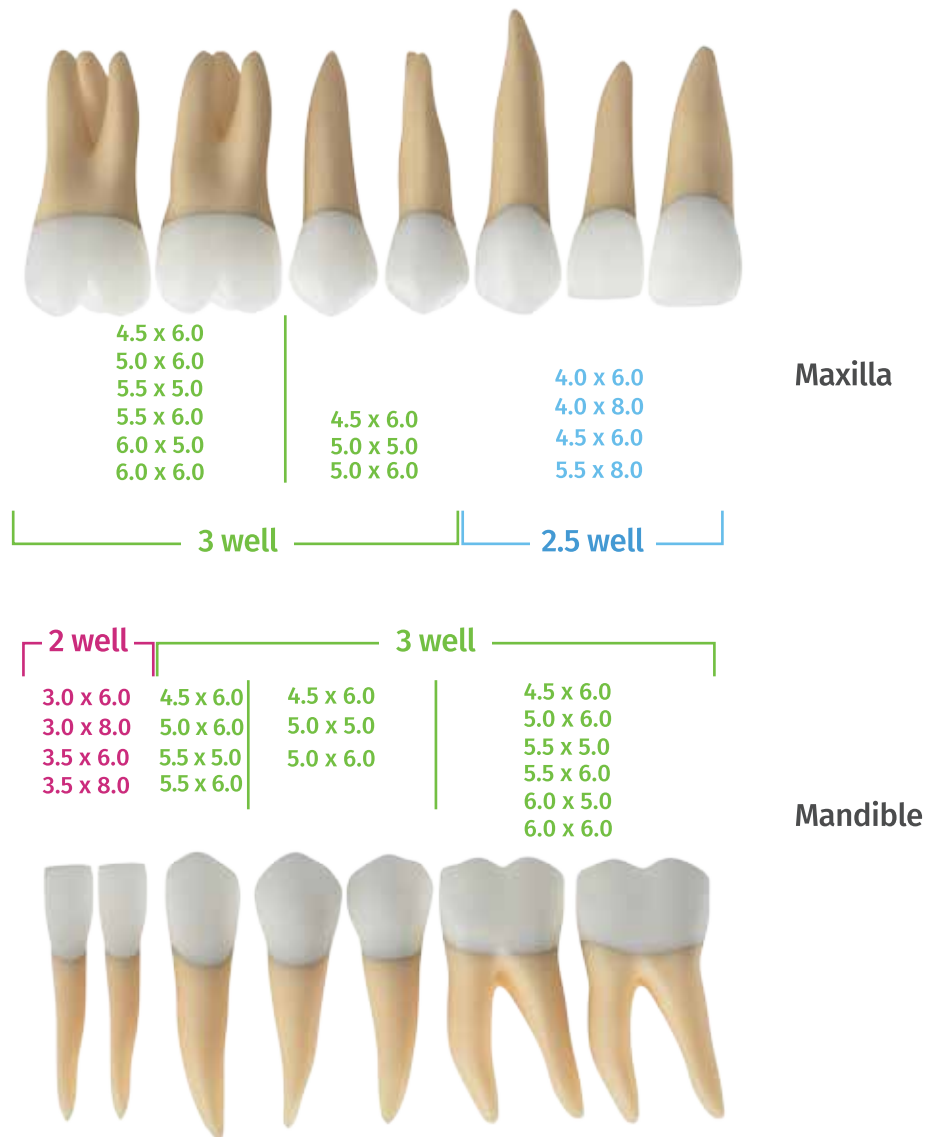

The chart above is for recommendation purposes only. The main criteria for choosing the appropriate implant size should be based on the clinician's assessment and patient characteristics.

ø3 and ø3.5mm implants are recommended for lateral & mandibular incisor teeth. If practical, their use should be avoided in other parts of the ridges.

It is advised to place 2.5 well implants (2.5 well) in the anterior maxilla.

It is recommended to have at least 1mm bone thickness around an implant. Therefore, 6mm hard tissue width can accommodate a ø4mm implant, otherwise alveolar ridge splitting or hard tissue grafting may be required.



i-system **IMPLANTS**

i-system implants eliminate the need for complex interventions and make the implant surgery a straightforward procedure, even in highly compromised cases.



**I-system implant
is the shortest bone level implant in the world**

PROSTHETIC COMPONENTS



PROSTHETIC COMPONENTS

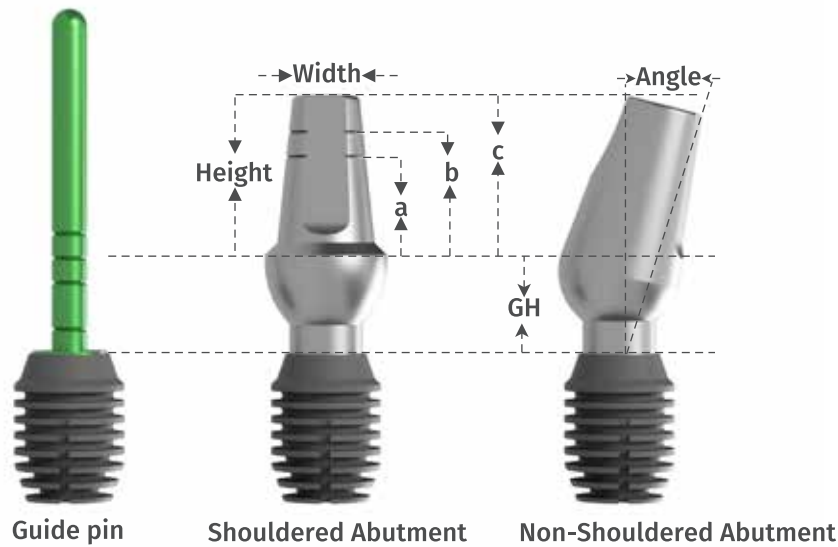

Width (W): The width of i-system abutments are between 4.0-6.5mm.

Height (H): a, b and c correspond to 4, 5 and 6mm above the abutment shoulder.

GH: Gingival height is the distance between the implant neck and the shoulder of the abutment and varies between 1 and 6mm.

Angle: The degree of angulation with the long axis of the implant.

Material: All the abutments of i-system are produced from highest quality titanium alloy (Ti-6Al-4V ELI, ASTM F136).

Marking lines over the guide pins can be used as a reference for appropriate GH selection. All i-system abutments are non-indexed and provide complete flexibility.

ABUTMENT CHART

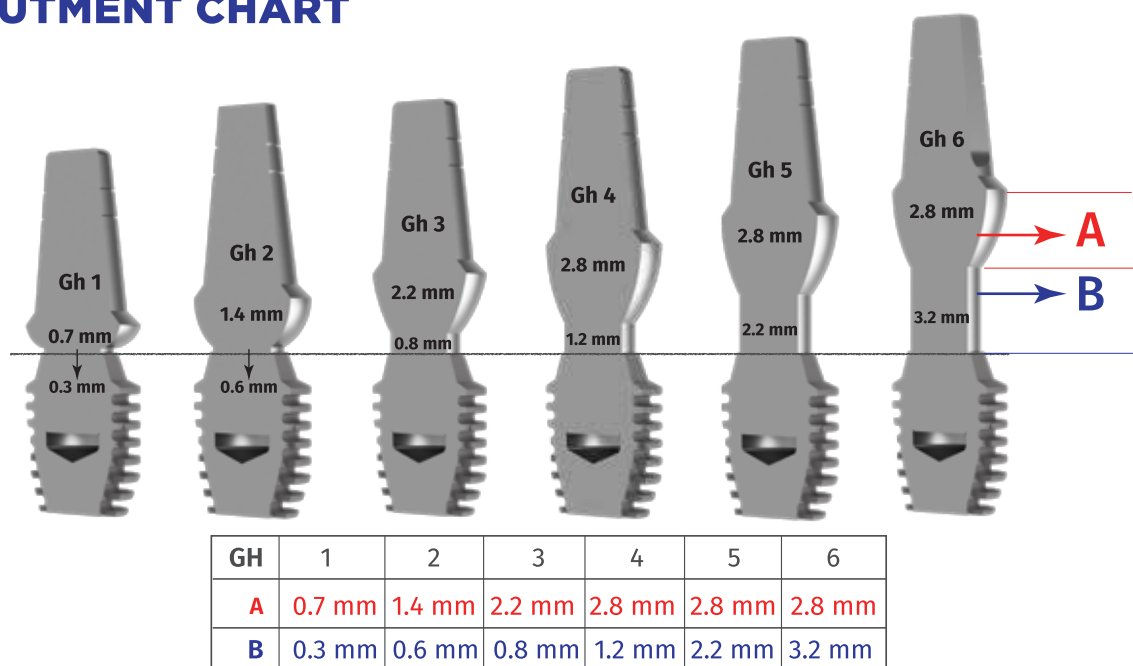

Post length of the abutments depend on the GH. In cases with subcrestal implant placement longer posts may eliminate the need for excessive bone removal over the implant.

2.0 WELL IMPLANTS

2.0 Well

implants

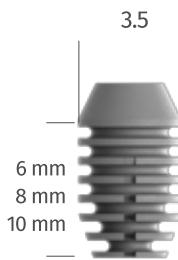
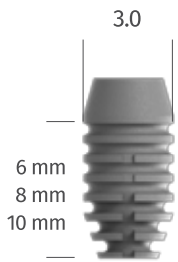

Healing Abutments



∅: 4 - 5 mm
GH: 4 - 6 mm

Cement retained

Shouldered



∅: 4 - 5 mm
GH: 1 mm
2 mm → 15°
 → 25°
3 mm
4 mm → 15°
 → 25°
5 mm
6 mm → 15°
 → 25°

Screw retained

Multi-Unit Abutment

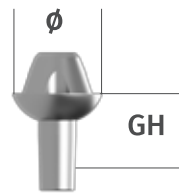

∅: 5 mm
GH: 1 mm
2 mm
3 mm → 17°
 → 33°
5 mm → 17°
 → 33°

Attachment retained

Ball Abutment	Locator Abutment
---------------	------------------

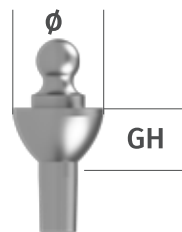

∅: 5 mm
GH: 1 - 2 - 3 - 4 - 5 - 6 mm



∅: 3.86 mm
GH: 2 - 4 - 6 mm



Non-Shouldered	Ti-Base Abutment	Impression	
		Implant Level	Abutment Level

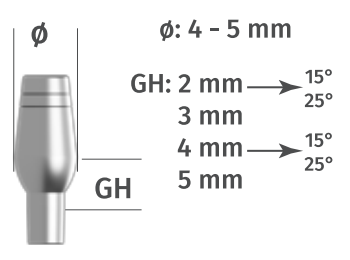

Multi-Unit Healing Cap	Multi Abutment Analog	Burn Out Cylinder	Impression Coping Pick-Up
------------------------	-----------------------	-------------------	---------------------------

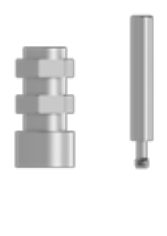
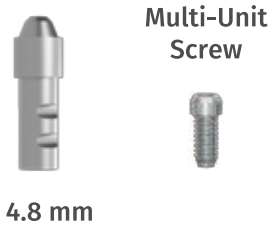

Locator Abutment Impressions	Ball Abutment Analog	Locator Abutment Analog	Attachment Components
------------------------------	----------------------	-------------------------	-----------------------



2.5 WELL IMPLANTS

2.5 Well

implants

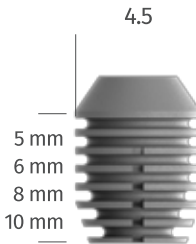
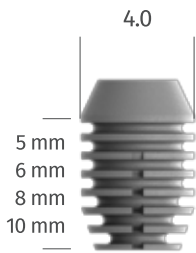

Healing Abutments



ϕ : 4 - 5 mm
GH: 4 - 6 mm

Cement retained

Shouldered



ϕ : 4 - 5 mm
GH: 1 mm
2 mm
3 mm
4 mm
5 mm
6 mm

Screw retained

Multi-Unit Abutment

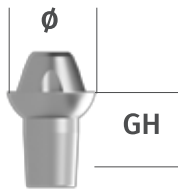

ϕ : 5 mm
GH: 1 mm
2 mm
3 mm
5 mm

Attachment retained

Ball Abutment

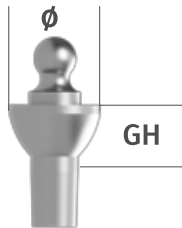

ϕ : 5 mm
GH: 1 - 2 - 3 - 4 - 5 - 6 mm

Locator Abutment



ϕ : 3.86 mm
GH: 2 - 4 - 6 mm



Non-Shouldered	Ti-Base Abutment	Impression	
		Implant Level	Abutment Level

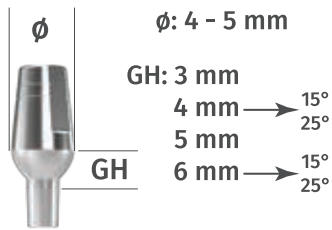

Only for $\phi: 4 - 5 \text{ mm}$

Multi-Unit Healing Cap	Multi Abutment Analog	Burn Out Cylinder	Impression Coping Pick-Up
------------------------	-----------------------	-------------------	---------------------------



$\phi: 5 \text{ mm}$



$\phi: 4.8 \text{ mm}$

Multi-Unit Screw



Burn Out Screw



Locator Abutment Impressions	Ball Abutment Analog	Locator Abutment Analog	Attachment Components
------------------------------	----------------------	-------------------------	-----------------------



$\phi: 4.1 \text{ mm}$



$\phi: 4.9 \text{ mm}$



Ball Housing



Ball inserts



Locator Housing



Locator inserts

3.0 WELL IMPLANTS

3.0 Well

implants

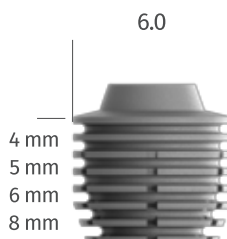
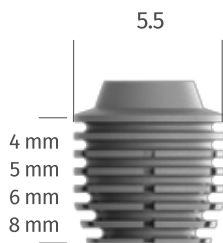
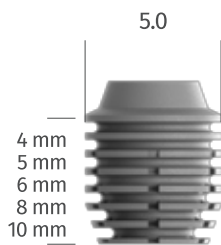
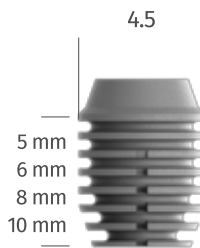
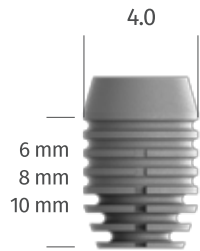

Healing Abutments



φ: 5 - 6.5 mm
GH: 4 - 6 mm

Cement retained

Shouldered

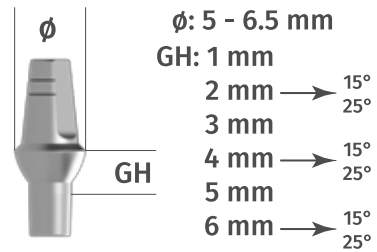

Screw retained

Multi-Unit Abutment

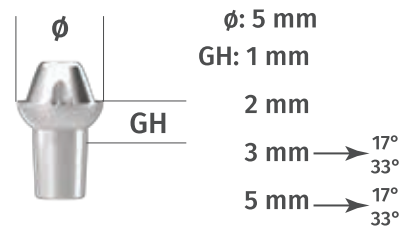

Attachment retained

Ball Abutment

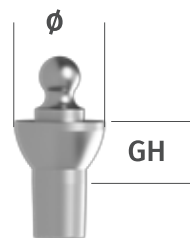

φ: 5 mm

GH: 1 - 2 - 3 - 4 - 5 - 6 mm

Locator Abutment



φ: 3.86 mm

GH: 2 - 4 - 6 mm

Non-Shouldered	Ti-Base Abutment	Impression	
		Implant Level	Abutment Level

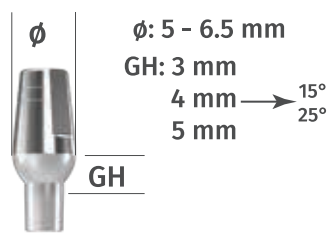

Only for φ: 4 - 5 mm

Multi-Unit Healing Cap	Multi Abutment Analog	Burn Out Cylinder	Impression Coping Pick-Up
------------------------	-----------------------	-------------------	---------------------------

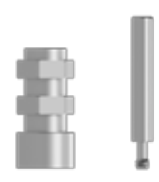
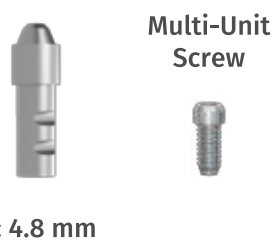

Locator Abutment Impressions	Ball Abutment Analog	Locator Abutment Analog	Attachment Components
------------------------------	----------------------	-------------------------	-----------------------



2.0 WELL IMPLANTS

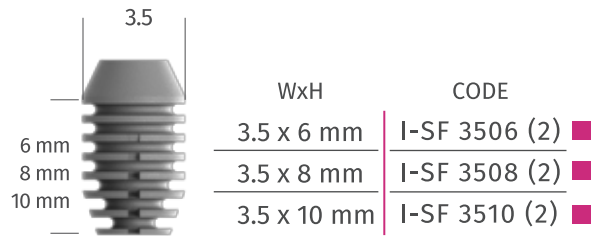
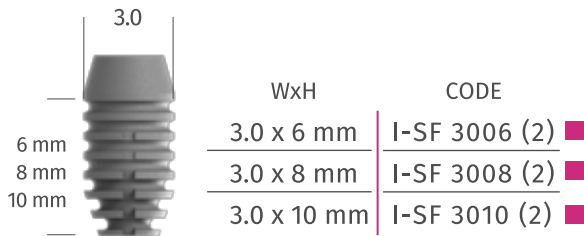

2.0 Post Shouldered Abutments

GH	WxH	Angle	Code	Angle	Code	Angle	Code
1	4.0 x 6.5	0	I-SSA 1040 (2)	-	-	-	-
	5.0 x 6.5	0	I-SSA 1050 (2)	-	-	-	-
2	4.0 x 6.5	0	I-SSA 2040 (2)	15	I-SSAA 2040-15 (2)	25	I-SSAA 2040-25 (2)
	5.0 x 6.5	0	I-SSA 2050 (2)	15	I-SSAA 2050-15 (2)	25	I-SSAA 2050-25 (2)
3	4.0 x 6.5	0	I-SSA 3040 (2)	-	-	-	-
	5.0 x 6.5	0	I-SSA 3050 (2)	-	-	-	-
4	4.0 x 6.5	0	I-SSA 4040 (2)	15	I-SSAA 4040-15 (2)	25	I-SSAA 4040-25 (2)
	5.0 x 6.5	0	I-SSA 4050 (2)	15	I-SSAA 4050-15 (2)	25	I-SSAA 4050-25 (2)
5	4.0 x 6.5	0	I-SSA 5040 (2)	-	-	-	-
	5.0 x 6.5	0	I-SSA 5050 (2)	-	-	-	-
6	4.0 x 6.5	0	I-SSA 6040 (2)	15	I-SSAA 6040-15 (2)	25	I-SSAA 6040-25 (2)
	5.0 x 6.5	0	I-SSA 6050 (2)	15	I-SSAA 6050-15 (2)	25	I-SSAA 6050-25 (2)



2.0 Post Non-Shouldered Abutments

GH	WxH	Angle	Code	Angle	Code	Angle	Code
2	4.0 x 7.5	0	I-SNSA 2040 (2)	15	I-SNSAA 2040-15 (2)	25	I-SNSAA 2040-25 (2)
	5.0 x 7.5	0	I-SNSA 2050 (2)	15	I-SNSAA 2050-15 (2)	25	I-SNSAA 2050-25 (2)
3	4.0 x 7.5	0	I-SNSA 3040 (2)	-	-	-	-
	5.0 x 7.5	0	I-SNSA 3050 (2)	-	-	-	-
4	4.0 x 7.5	0	I-SNSA 4040 (2)	15	I-SNSAA 4040-15 (2)	25	I-SNSAA 4040-25 (2)
	5.0 x 7.5	0	I-SNSA 4050 (2)	15	I-SNSAA 4050-15 (2)	25	I-SNSAA 4050-25 (2)
5	4.0 x 7.5		I-SNSA 5040 (2)	-	-	-	-
	5.0 x 7.5		I-SNSA 5050 (2)	-	-	-	-





Locator Abutments

GH	W	Code
2	3,86	I-SLA 20 (2)
4	3,86	I-SLA 40 (2)
6	3,86	I-SLA 60 (2)



Ball Abutments

GH	W	Code
1	5	I-SBA 10 (2)
2	5	I-SBA 20 (2)
3	5	I-SBA 30 (2)
4	5	I-SBA 40 (2)
5	5	I-SBA 50 (2)
6	5	I-SBA 60 (2)



Healing Abutments

GH	W	Code
4	4.0	I-SHA 4040 (2)
	5.0	I-SHA 4050 (2)
6	4.0	I-SHA 6040 (2)
	5.0	I-SHA 6050 (2)



Multi-Unit Angle Abutments

GH	W	Angle	Code
3	5	17	I-SMUA 3050-17 (2)
5	5	17	I-SMUA 5050-17 (2)
3	5	33	I-SMUA 3050-33 (2)
5	5	33	I-SMUA 5050-33 (2)

Locator Abutment Retainers

I-SLAR



Ball Abutment Retainers

I-SRAR

Titanium Housing



Ti-Base Abutments

GH	W	Code
1	1.0 x 4.5	I-STiA 1045 (2)
2	2.0 x 4.5	I-STiA 2045 (2)
3	3.0 x 4.5	I-STiA 3045 (2)



Multi-Unit Abutments

GH	W	Code
1	5	I-SMUA 1050 (2)
2	5	I-SMUA 2050 (2)
3	5	I-SMUA 3050 (2)
5	5	I-SMUA 5050 (2)

Impression Components - Analog

Bone Level Implant
Impression

Fixture Analogs

I-SIPc (2) I-SIP (2)

I-SFA (2)

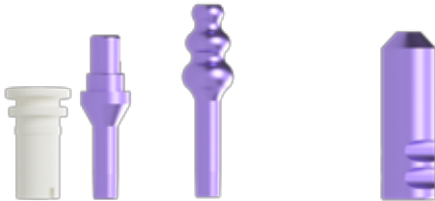

Shouldered Abutment Analog

WxH	CODE
4.0 x 6.5	I-SSAA 4065
5.0 x 6.5	I-SSAA 5065
6.5 x 6.5	I-SSAA 6565



Abutment Level Impression Cap

WxH	CODE
4.0 x 6.5	I-SAICP 40
5.0 x 6.5	I-SAICP 50
6.5 x 6.5	I-SAICP 65

Ring Abutment Analog

I-SRAA



Locator Abutment Analog

I-SLAA



Impression Coping Pick-Up

I-SMUAIP



Multi-Unit Abutment Analog

I-SMUALA



Multi-Unit
Screw

Burn Out Cylinder





I-SMUAPICYN







Burn Out
Screw



2.5 WELL IMPLANTS

4.0		WxH	CODE
5 mm		4.0 x 5 mm	I-SF 4005 (2.5) ■
6 mm		4.0 x 6 mm	I-SF 4006 (2.5) ■
8 mm		4.0 x 8 mm	I-SF 4008 (2.5) ■
10 mm		4.0 x 10 mm	I-SF 4010 (2.5) ■

4.5		WxH	CODE
5 mm		4.5 x 5 mm	I-SF 4505 (2.5) ■
6 mm		4.5 x 6 mm	I-SF 4506 (2.5) ■
8 mm		4.5 x 8 mm	I-SF 4508 (2.5) ■
10 mm		4.5 x 10 mm	I-SF 4510 (2.5) ■



2.5 Post Non-Shouldered Abutments

GH	WxH	Angle	Code	Angle	Code	Angle	Code
3	4.0 x 7.5	0	I-SNSA 3040 (2.5)	-	-	-	-
	5.0 x 7.5	0	I-SNSA 3050 (2.5)	-	-	-	-
4	4.0 x 7.5	0	I-SNSA 4040 (2.5)	15	I-SNSAA 4040-15 (2.5)	25	I-SNSAA 4040-25 (2.5)
	5.0 x 7.5	0	I-SNSA 4050 (2.5)	15	I-SNSAA 4050-15 (2.5)	25	I-SNSAA 4050-25 (2.5)
5	4.0 x 7.5	0	I-SNSA 5040 (2.5)	-	-	-	-
	5.0 x 7.5	0	I-SNSA 5050 (2.5)	-	-	-	-
6	4.0 x 7.5	0	I-SNSA 6040 (2.5)	15	I-SNSAA 6040-15 (2.5)	25	I-SNSAA 6040-25 (2.5)
	5.0 x 7.5	0	I-SNSA 6050 (2.5)	15	I-SNSAA 6050-15 (2.5)	25	I-SNSAA 6050-25 (2.5)

2.5 post abutments are recommended to be used with 2.5 well implants in maxillary anterior region.



2.5 Post Shouldered Abutments

GH	WxH	Angle	Code
1	4.0 x 6.5	0	I-SSA 1040 (2.5)
	5.0 x 6.5	0	I-SSA 1050 (2.5)
2	4.0 x 6.5	0	I-SSA 2040 (2.5)
	5.0 x 6.5	0	I-SSA 2050 (2.5)
3	4.0 x 6.5	0	I-SSA 3040 (2.5)
	5.0 x 6.5	0	I-SSA 3050 (2.5)
4	4.0 x 6.5	0	I-SSA 4040 (2.5)
	5.0 x 6.5	0	I-SSA 4050 (2.5)
5	4.0 x 6.5	0	I-SSA 5040 (2.5)
	5.0 x 6.5	0	I-SSA 5050 (2.5)
6	4.0 x 6.5	0	I-SSA 6040 (2.5)
	5.0 x 6.5	0	I-SSA 6050 (2.5)



Locator Abutments

GH	W	Code
2	3,86	I-SLA 20 (2.5)
4	3,86	I-SLA 40 (2.5)
6	3,86	I-SLA 60 (2.5)

Locator Abutment Retainers

I-SLAR



Ball Abutments

GH	W	Code
1	5	I-SBA 10 (2.5)
2	5	I-SBA 20 (2.5)
3	5	I-SBA 30 (2.5)
4	5	I-SBA 40 (2.5)
5	5	I-SBA 50 (2.5)
6	5	I-SBA 60 (2.5)

Ball Abutment Retainers

I-SRAR

Titanium Housing



Healing Abutments

GH	W	Code
4	4.0	I-SHA 4040 (2.5)
	5.0	I-SHA 4050 (2.5)
6	4.0	I-SHA 6040 (2.5)
	5.0	I-SHA 6050 (2.5)



Ti-Base Abutments

GH	W	Code
1	1.0 x 4.5	I-STiA 1045 (2.5)
2	2.0 x 4.5	I-STiA 2045 (2.5)
3	3.0 x 4.5	I-STiA 3045 (2.5)



Multi-Unit Abutments

GH	W	Code
1	5	I-SMUA 1050 (2.5)
2	5	I-SMUA 2050 (2.5)
3	5	I-SMUA 3050 (2.5)
5	5	I-SMUA 5050 (2.5)



Impression Components - Analog

Bone Level Implant
impression

Fixture Analogs

I-SIPc (2.5)

I-SIP (2.5)

I-SFA (2.5)

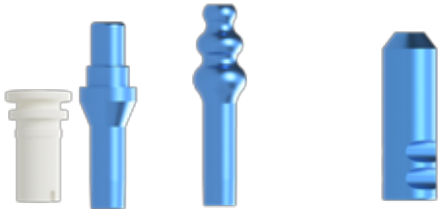

Abutment Level Impression Cap

WxH	CODE
4.0 x 6.5	I-SAICP 40
5.0 x 6.5	I-SAICP 50
6.5 x 6.5	I-SAICP 65



Shouldered Abutment Analog

WxH	CODE
5.0 x 6.5	I-SSAA 5065
6.5 x 6.5	I-SSAA 6565

Ball Abutment Analog

I-SRAA



Locator Abutment Analog

I-SLAA



Impression Coping Pick-Up

I-SMUAIP

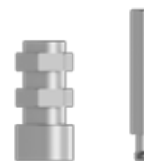

Multi-Unit Abutment Analog

I-SMUALA



Multi-Unit
Screw



Burn Out Cylinder

I-SMUAPICYN



Burn Out
Screw



3.0 WELL IMPLANTS

4.0

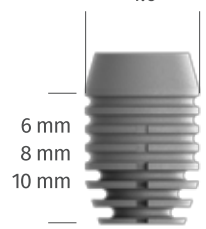

WxH	CODE
4.0 x 6 mm	I-SF 4006 (3) ■
4.0 x 8 mm	I-SF 4008 (3) ■
4.0 x 10 mm	I-SF 4010 (3) ■

4.5

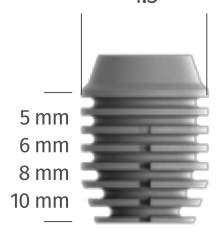

WxH	CODE
4.5 x 5 mm	I-SF 4505 (3) ■
4.5 x 6 mm	I-SF 4506 (3) ■
4.5 x 8 mm	I-SF 4508 (3) ■
4.5 x 10 mm	I-SF 4510 (3) ■

5.0

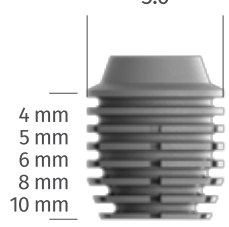

WxH	CODE
5.0 x 4 mm	I-SF 5004 (3) ■
5.0 x 5 mm	I-SF 5005 (3) ■
5.0 x 6 mm	I-SF 5006 (3) ■
5.0 x 8 mm	I-SF 5008 (3) ■
5.0 x 10 mm	I-SF 5010 (3) ■

5.5

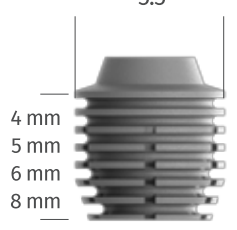

WxH	CODE
5.5 x 4 mm	I-SF 5504 (3) ■
5.5 x 5 mm	I-SF 5505 (3) ■
5.5 x 6 mm	I-SF 5506 (3) ■
5.5 x 8 mm	I-SF 5508 (3) ■

6.0

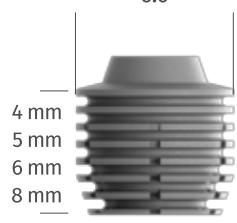

WxH	CODE
6.0 x 4 mm	I-SF 6004 (3) ■
6.0 x 5 mm	I-SF 6005 (3) ■
6.0 x 6 mm	I-SF 6006 (3) ■
6.0 x 8 mm	I-SF 6008 (3) ■





3.0 Post Shouldered Abutments

GH	WxH	Angle	Code	Angle	Code	Angle	Code
1	5.0 x 6.5	0	I-SSA 1050 (3)	-	-	-	-
	6.5 x 6.5	0	I-SSA 1065 (3)	-	-	-	-
2	5.0 x 6.5	0	I-SSA 2050 (3)	15	I-SSAA 2050-15 (3)	25	I-SSAA 2050-25 (3)
	6.5 x 6.5	0	I-SSA 2065 (3)	15	I-SSAA 2065-15 (3)	25	I-SSAA 2065-25 (3)
3	5.0 x 6.5	0	I-SSA 3050 (3)	-	-	-	-
	6.5 x 6.5	0	I-SSA 3065 (3)	-	-	-	-
4	5.0 x 6.5	0	I-SSA 4050 (3)	15	I-SSAA 4050-15 (3)	25	I-SSAA 4050-25 (3)
	6.5 x 6.5	0	I-SSA 4065 (3)	15	I-SSAA 4065-15 (3)	25	I-SSAA 4065-25 (3)
5	5.0 x 6.5	0	I-SSA 5050 (3)	-	-	-	-
	6.5 x 6.5	0	I-SSA 5065 (3)	-	-	-	-
6	5.0 x 6.5	0	I-SSA 6050 (3)	15	I-SSAA 6050-15 (3)	25	I-SSAA 6050-25 (3)
	6.5 x 6.5	0	I-SSA 6065 (3)	15	I-SSAA 6065-15 (3)	25	I-SSAA 6065-25 (3)



3.0 Post Non-Shouldered Abutments

GH	WxH	Angle	Code	Angle	Code	Angle	Code
3	5.0 x 7.5	0	I-SNSA 3050 (3)	-	-	-	-
	6.5 x 7.5	0	I-SNSA 3065 (3)	-	-	-	-
4	5.0 x 7.5	0	I-SNSA 4050 (3)	15	I-SNSAA 4050-15 (3)	25	I-SNSAA 4050-25 (3)
	6.5 x 7.5	0	I-SNSA 4065 (3)	15	I-SNSAA 4065-15 (3)	25	I-SNSAA 4065-25 (3)
5	5.0 x 7.5	0	I-SNSA 5050 (3)	-	-	-	-
	6.5 x 7.5	0	I-SNSA 5065 (3)	-	-	-	-



Sinus Abutment

W	L	Code
5	6.5	I-SSINA 5065 (3)
6	7.5	I-SSINA 6075 (3)



Locator Abutments

GH	W	Code
2	3,86	I-SLA 20 (3)
4	3,86	I-SLA 40 (3)
6	3,86	I-SLA 60 (3)

Locator Abutment Retainers

I-SLAR



Ball Abutments

GH	W	Code
1	5	I-SBA 10 (3)
2	5	I-SBA 20 (3)
3	5	I-SBA 30 (3)
4	5	I-SBA 40 (3)
5	5	I-SBA 50 (3)
6	5	I-SBA 60 (3)

Ball Abutment Retainers

I-SRAR

Titanium
Housing



Healing Abutments

GH	W	Code
4	4.0	I-SHA 4040 (3)
	5.0	I-SHA 4050 (3)
6	4.0	I-SHA 6040 (3)
	5.0	I-SHA 6050 (3)



Ti-Base Abutments

GH	W	Code
1	1.0 x 4.5	I-STiA 1045 (3)
2	2.0 x 4.5	I-STiA 2045 (3)
3	3.0 x 4.5	I-STiA 3045 (3)



Multi-Unit Angle Abutments

GH	W	Angle	Code
3	5	17	I-SMUA 3050-17 (3)
5	5	17	I-SMUA 5050-17 (3)
3	5	33	I-SMUA 3050-33 (3)
5	5	33	I-SMUA 5050-33 (3)



Multi-Unit Abutments

GH	W	Code
1	5	I-SMUA 1050 (3)
2	5	I-SMUA 2050 (3)
3	5	I-SMUA 3050 (3)
5	5	I-SMUA 5050 (3)



Impression Components - Analog

Bone Level Implant impression		Fixture Analogs
I-SIPc (3)	I-SIP (3)	I-SFA (3)

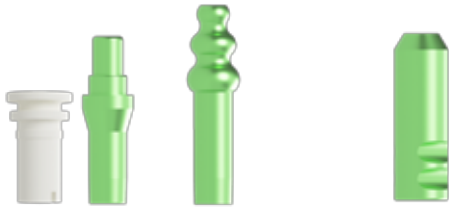

Shouldered Abutment Analog

WxH	CODE
4.0 x 6.5	I-SSAA 4065
5.0 x 6.5	I-SSAA 5065
6.5 x 6.5	I-SSAA 6565



Abutment Level Impression Cap

WxH	CODE
4.0 x 6.5	I-SAICP 40
5.0 x 6.5	I-SAICP 50
6.5 x 6.5	I-SAICP 65

Ball Abutment Analog

I-SRAA



Locator Abutment Analog

I-SLAA



Impression Coping Pick-Up

I-SMUAIP

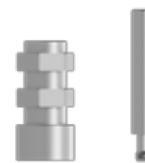

Multi-Unit Abutment Analog

I-SMUALA



Burn Out Cylinder

I-SMUAPICYN





SURGICAL PROTOCOL



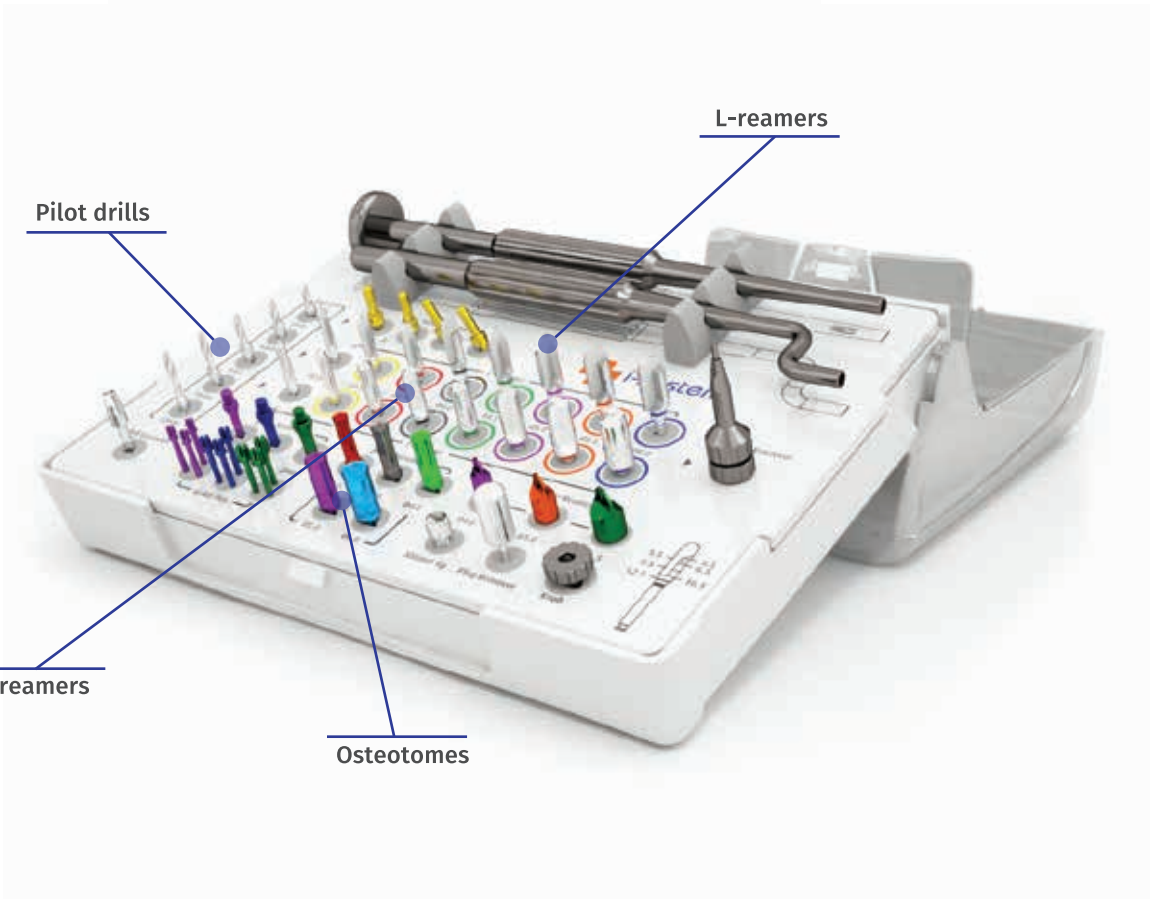

INTRODUCTION

i-system dental implants are indicated to be used in the upper or lower jaw to act as artificial roots / fixtures for single or multiple-unit fixed prosthetic reconstructions, or to support partially or fully removable over-dentures, restoring a patient's chewing function.

A two-stage surgical procedure is recommended for i-system, and primary wound closure should be achieved in all cases. Loading during the osseointegration period should be avoided. i-system implants are bone level press-fit implants with parallel plates (in place of the traditional helical thread), a sloping shoulder, and an internal well. The implant-abutment connection is friction-fit, the post of the abutment fits precisely into the well of the implant forming a so-called "cold-weld" connection. Therefore, all abutments function without the need of an abutment screw.

i-system abutments connect the implant with the prosthetic reconstruction, to restore chewing function, phonation and aesthetic appearance of the patient.

i-system abutments are to be used with an i-system dental implant, to support prosthetic restorations such as crowns, bridges and over-dentures in partially or fully edentulous patients. The well's size differs depending on the diameter of an implant, which determines the size of the appropriate abutment post.

Second stage surgery should occur after an appropriate period for osseointegration. In the second surgery, the cover plug is removed, and a healing cap is placed to facilitate proper transmucosal healing. The healing cap is a temporary component and is replaced with a permanent abutment after the soft tissue has healed, impressions have been taken, and the lab work is complete. Impressions can be taken at implant or abutment level, requiring different components and protocols. Implant level impressions require the use of an impression post and cap.

An abutment analogue or an implant analogue is used during casting. The final prosthetic reconstructions are either made on the abutment analogue or directly on the permanent abutment placed in an implant analogue. The final prosthesis is fabricated on plaster cast models.



i-system implants with a 2mm well should not be used in posterior areas as a single unit restoration and should not be used with over-denture attachments. Implants with a 2.5mm well should be used only in anterior maxillary areas, and implants with a 3mm well are indicated for all regions. 4mm length implants should not be used as a single unit reconstruction. Ø3mm implants should be used only for lower incisors or upper lateral incisors with narrow crowns.

Dental implant surgery and the subsequent prosthetic stages are complex dental interventions. Appropriate and adequate training is needed before any implant placements. Only an experienced practitioner should place and restore the implants.

Surgical Protocol

The i-system surgical kit contains all the drills and auxiliary components needed to prepare an osteotomy and place an i-system implant. Each surgical kit contains pilot drills, L-reamers, and i-reamers which each have different specifications and are used to prepare the implant osteotomy. All of the drills are produced from high-quality stainless steel to guarantee long-lasting clinical performance.

Pilot Drills

There are different lengths of depth stop pilot drills and also a pilot drill without any stopper. The depth stop drills help prevent over-penetration, and the non-depth-stop drill is for use in areas where a deeper, more subcrestal placement is needed. The pilot drills should be used at 600rpm with saline irrigation to prevent overheating. In cases with low-density bone such as in posterior maxillary areas, the pilot drill can be used below 50rpm and without cooling irrigation.



DIGITAL SOLUTION



CUSTOM ABUTMENT

i-system premill custom abutments are completely "patient-specific" abutments produced according to the patient's teeth and gum dimensions.



ADVANTAGES

Dental labs are increasingly dealing with customized restoration services. i-system Digital Solutions offer CAD-CAM designed products for all cases, from traditional implant-borne solutions to tooth-borne restorations, that you can easily obtain. You can get i-system quality customized abutments, whether you prefer digital or traditional working methods.

i-system custom abutments offer several advantages:

- Perfect fit between implant-abutment-gum.
- Solutions for problematic angles, location or anatomy.
- An ideal gum and neck line.
- A broad range of material options.
- Aesthetical superiority.

An STL file is all that's needed to get started.



CAD/CAM System



Scanning the impression taken from the patient or, scanning the prepared implant cast using a 3D scanner,

Designing abutment dimensions according to the patient's needs, using CAD software,

Using CAM system to produce a completely patient-specific custom abutment.

Custom abutments are produced and designed without any margin of error. They are machined with pre-milled internal connections which consistently provide a perfect seating at the abutment-implant connection point.

DIGITAL ACCESSORIES



Scan body



Digital Lab Analog



Ti-base

The i-system library for Exocad, containing scan bodies, ti-bases and pre-mills, are available for download. i-system libraries are free and technical drawings are open for public use.



PREMILLS

W	Code	Code	Code
10	■ I-SPA10 (2)	■ I-SPA10 (2.5)	■ I-SPA10 (3)
14	■ I-SPA14 (2)	■ I-SPA14 (2.5)	■ I-SPA14 (3)
16	■ I-SPA16 (2)	■ I-SPA16 (2.5)	■ I-SPA16 (3)



DIGITAL LAB-ANALOG

	Well	Code
■	2	I-SDLab (2)
■	2.5	I-SDLab (2.5)
■	3	I-SDLab (3)



SCAN BODY

	Well	Code
■	2	I-PSB (2)
■	2.5	I-PSB (2.5)
■	3	I-PSB (3)

L-reamers

L-reamers have two sharp edges and symmetrically enlarge the osteotomy site. L-reamers are used below 50 rpm and no saline cooling is required. Autogenous bone particles can be harvested from the three chambers of the drill during the drilling process, which can then be used as a graft material in bone regeneration.

The reamer's tip is blunt, so unless the bone density is very low and significant vertical force isn't applied, the L-reamers cannot deepen the osteotomy. The drill's outer shape matches the implant, and therefore the last drill should have the same diameter as the implant being placed.

L-reamers may be used with either a contra-angle handpiece or the straight handle in the surgical kit.

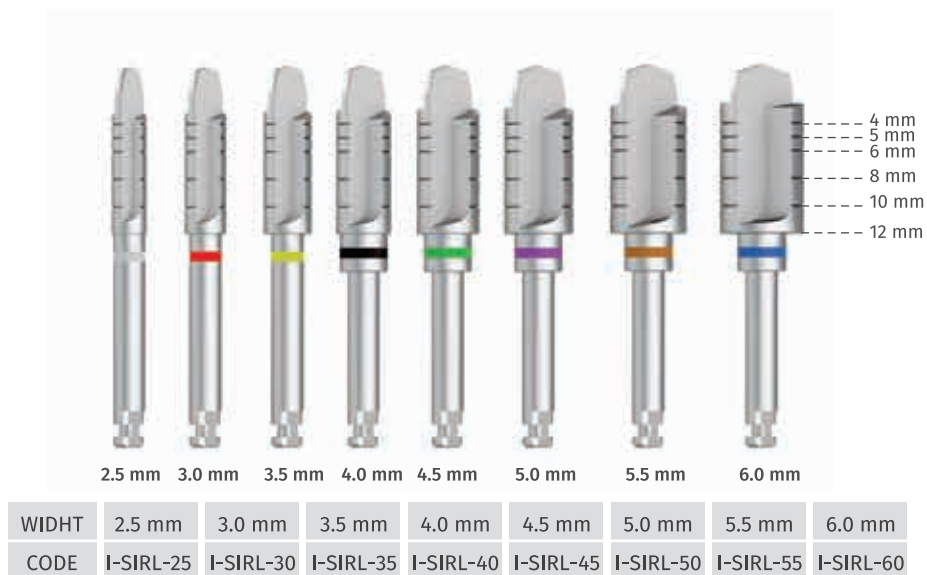

i-reamers

I-reamers have a single sharp edge and therefore enlarge the osteotomy site slower compared to L-reamers. I-reamers are used below 40 rpm and no saline cooling is required. The tip of the i-reamer is sharp and may deepen the osteotomy easily.

In case of having a shallow osteotomy or when selective deepening is required, such as being close to the mandibular nerve or maxillary sinuses, i-reamers may be preferable. The sharp tip's outward inclination decreases the perforation risk of the maxillary sinus membrane and helps to elevate the sinus floor internally. When measured bone removal is needed from any osteotomy, an i-reamer of the corresponding size should be used.

If an i-reamer is used as the final drill, the implant diameter should match the diameter of the i-reamer. In cases with low-density bone, i-reamers can be used anti-clockwise to condense the supporting bone in the osteotomy, using the contra-angle or with the straight handle, as a bone condenser.

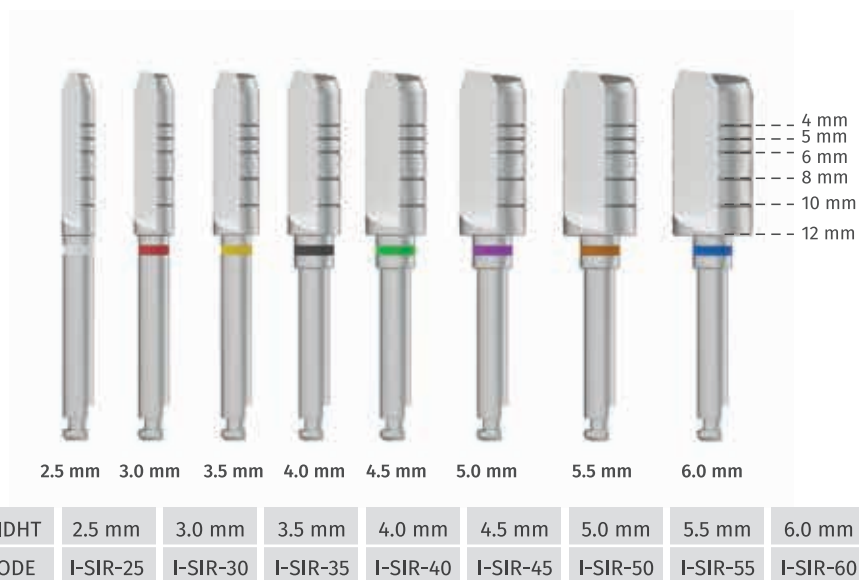

Surgical steps

The first osteotomy is made using saline irrigation with the pilot drill at around 600rpm. It is recommended to prepare the depth of the osteotomy in repeated apical-coronal movements rather than a single apical action, to avoid excessive heat. Where the osteotomy dimensions allow, the implant should be placed 1mm sub-crestally; and so a depth stop pilot drill one size longer should be used to prepare the deeper osteotomy. A paralleling pin is then placed into the osteotomy to check the position and the angulation. An x-ray can be taken to evaluate the location with neighbouring anatomical structures if needed. In case of incorrect alignment, the pilot drill is side cutting so can be used to change the angle of the osteotomy, which should then be re-checked with a paralleling pin.

The osteotomy is then continued using the L-reamers. L-reamers work below 50rpm and do not require saline irrigation. If deepening of the osteotomy is necessary and selective bone removal is needed, i-reamers should be preferred. Having a single sharp edge may increase the risk of overheating therefore i-reamers should not exceed 40rpm. Both reamers can be used with the straight handle, and when preparing an osteotomy in the maxilla, the handle may increase the manipulation capability. I-reamers and L-reamers should follow the consecutive width order until the implant's desired diameter is achieved. i-system implants should ideally be placed 1mm sub-crestally when sufficient hard tissue volume is present. Therefore the depth of the osteotomy to the crest should exceed the length of the implant. After the osteotomy's width and depth have been achieved, the whole site should be thoroughly rinsed with saline solution, or a surgical curette should be gently used to remove any excess bone particles remaining inside the osteotomy to prevent interference and shallow implant placement.

The implant is carried into the osteotomy site either using the plastic carrier available in the implant package, or the inserter & retriever tool present in the surgical kit. During implant insertion, a shaking and rotating movement may help to position the implant in place correctly. Should the implant not seat properly, a seating tip is used to tap the implant gently. Applying high tapping force may damage the osteotomy, change the direction of implant angulation and damage the well's base and so should be avoided. Especially when placing 4mm long implants, excessive tapping force may result in plastic deformation.

After the implant is seated, a guide pin is placed into the well to check the angulation. A lateral force can be applied to correct the angulation when necessary. Angulation problems in implants <6mm are easier to correct at this stage, however longer implants are more resistant and may require removal and reshaping of the osteotomy. If the implant is placed no more than 1mm sub-crestally, the black peek cover plug inside the package is inserted to seal the well. If the implant is placed deeper, the plastic plug should be cut at bone level, after it has been secured in the well of the implant. The autogenous bone harvested during the osteotomy should be used to cover the implant's sloping shoulders to allow for optimum implant coverage and integration. Finally when suturing, a tension-free flap should be achieved, and total primary wound covering / healing should be achieved for the best predictable, successful osseointegration.



SURGICAL STEPS

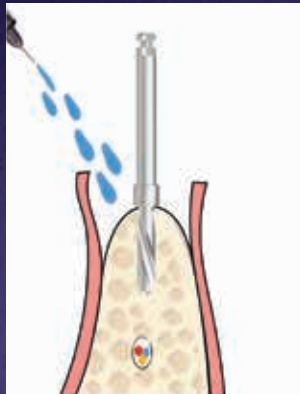

Drill the 2.0mm pilot hole with external irrigation to a depth 1.0mm–2.0mm deeper than the length of the implant when anatomically possible. Choose the appropriate depth stop pilot drill to ensure the correct depth of the osteotomy

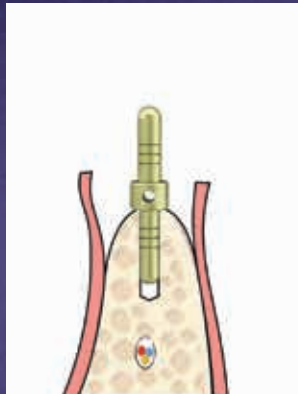

Use paralleling pins to evaluate the depth and alignment. Use the pilot drill to correct the angulation if necessary.

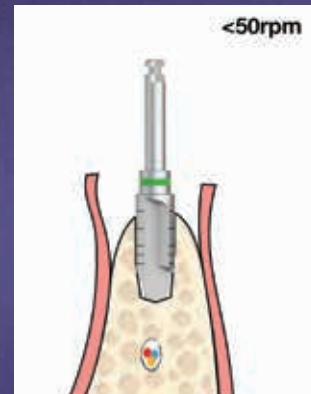

Widen the socket using sequentially larger drills without irrigation and below 50 RPM.



Harvest autogenous bone collected with i-reamer and L-reamers during the drilling process.

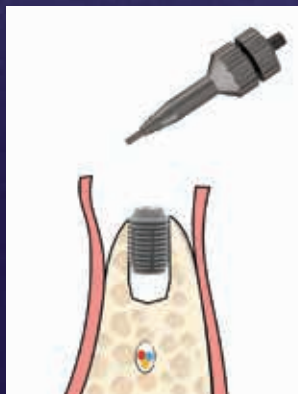

Remove the implant from the PEEK packaging, either using the plastic plug or the transfer/ retrieval tool, to place the implant into the osteotomy

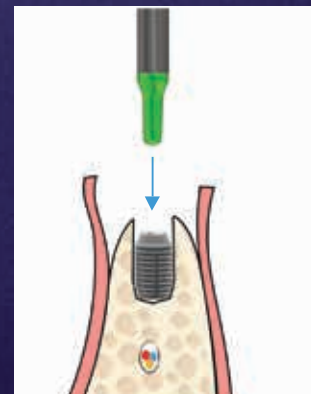

Seat the implant with appropriate seating tip if necessary.

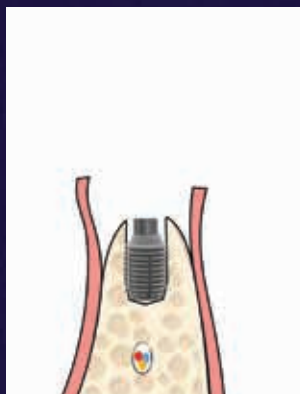

Use the peek or plastic plug to cover the well of the implant.

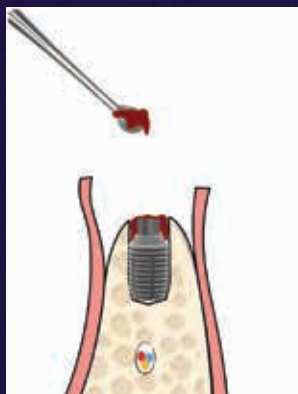

Place the harvested bone over the shoulders of the implant.

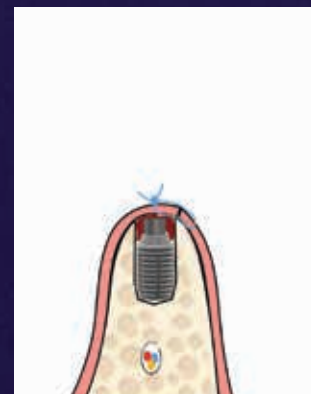

Suture the flap appropriately.

Guide Pin

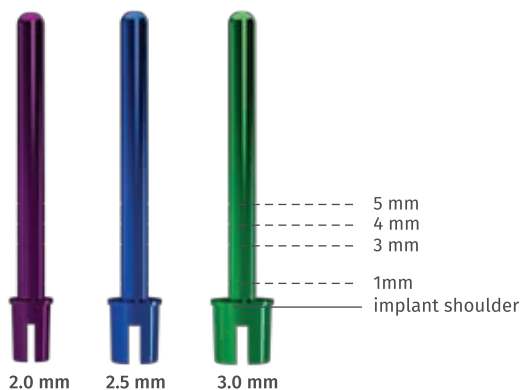

POST	2.0 well	2.5 well	3.0 well
CODE	I-SGP-20	I-SGP-25	I-SGP-30

Paralleling Pins

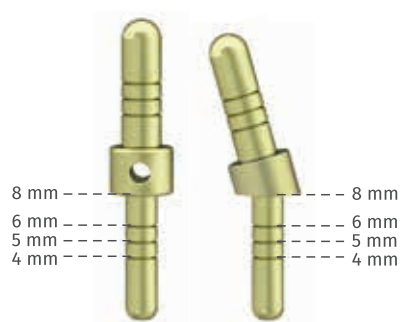

Name	Straight	Angled (15)
CODE	I-SPP-0	I-SPP-15

Profile Reamers

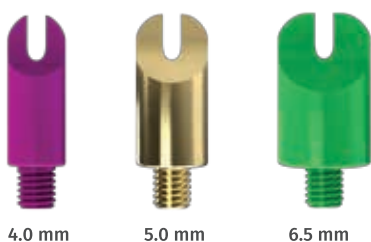

WIDTH	4.0 mm	5.0 mm	6.5 mm
CODE	I-SSR-40	I-SSR-50	I-SSR-65

Seating Tips



POST	2.0well	2.5well	3.0well
CODE	I-SST-20	I-SST-25	I-SST-30

Osteotomes



WIDTH	3.5 mm	4.0 mm	4.5 mm	5.0 mm	6.0 mm
CODE	I-SOST-35	I-SOST-40	I-SOST-45	I-SOST-50	I-SOST-60



Knob



CODE I-SKNB

Abutment tip



CODE I-SAT

Drill Extension



CODE I-SDE

Plug Remover



CODE I-SPR
I-SPRS

Universal Inserter Retriever



CODE I-SUIR

Dental Hammer



CODE I-SHMR

Abutment Handle



CODE I-SAH

Dental Scissor



CODE I-SCS

Straight Handle



CODE I-SSH

Curved Handle



CODE I-SCH

Mandibular Extraction Forceps



CODE I-SFRCU

Maxillary Extraction Forceps



CODE I-SFRCL

Surgical Steps Follow Chart

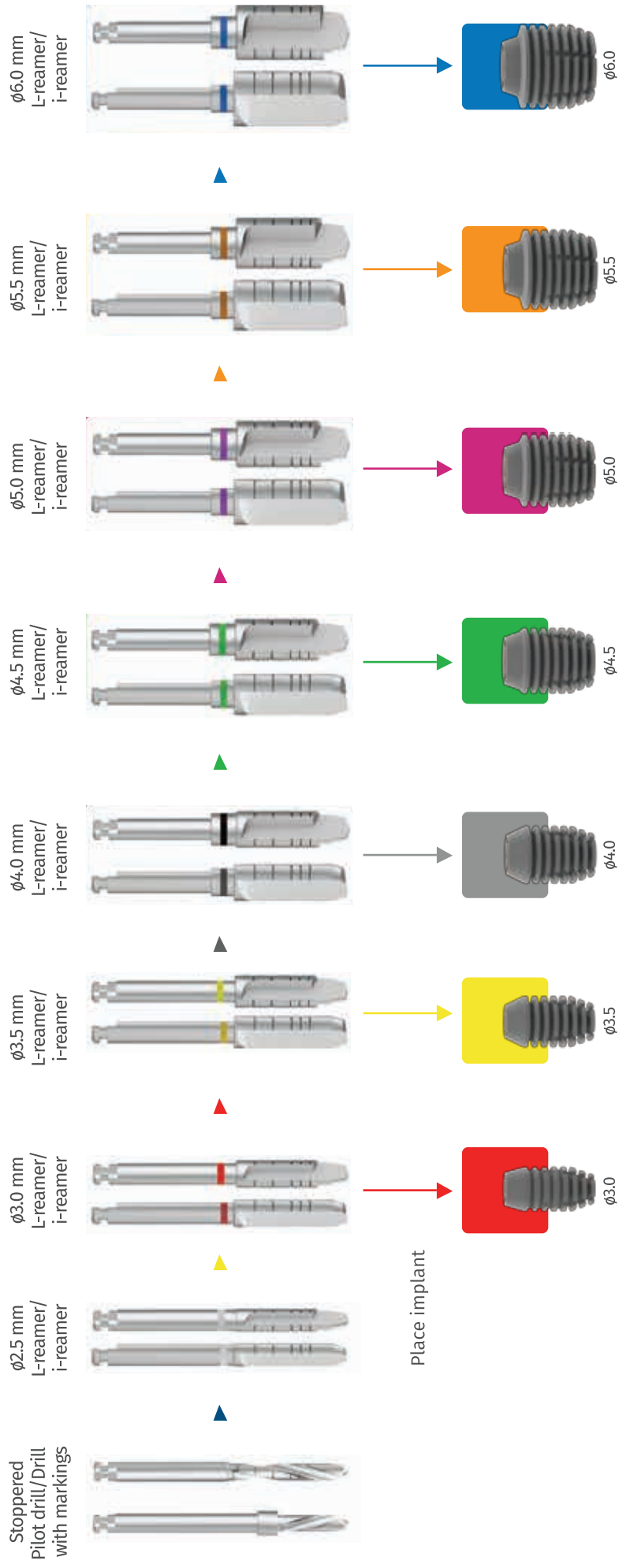



I-SYSTEM INDEX CODE

PRODUCT	WIDTH	HEIGHT	CODE
FIXTURES			
2.0 WELL IMPLANTS			
2.0 Well Implants	∅ 3.0	6.0 mm	I-SF3006 (2)
2.0 Well Implants	∅ 3.0	8.0 mm	I-SF3008 (2)
2.0 Well Implants	∅ 3.0	10 mm	I-SF3010 (2)
2.0 Well Implants	∅ 3.5	6.0 mm	I-SF3506 (2)
2.0 Well Implants	∅ 3.5	8.0 mm	I-SF3508 (2)
2.0 Well Implants	∅ 3.5	10 mm	I-SF3510 (2)
2.5 WELL IMPLANTS			
2.5 Well Implants	∅ 4.0	5.0 mm	I-SF4005 (2.5)
2.5 Well Implants	∅ 4.0	6.0 mm	I-SF4006 (2.5)
2.5 Well Implants	∅ 4.0	8.0 mm	I-SF4008 (2.5)
2.5 Well Implants	∅ 4.0	10 mm	I-SF4010 (2.5)
2.5 Well Implants	∅ 4.5	5.0 mm	I-SF4505 (2.5)
2.5 Well Implants	∅ 4.5	6.0 mm	I-SF4506 (2.5)
2.5 Well Implants	∅ 4.5	8.0 mm	I-SF4508 (2.5)
2.5 Well Implants	∅ 4.5	10 mm	I-SF4510 (2.5)
3.0 WELL IMPLANTS			
3.0 Well Implants	∅ 4.0	6.0 mm	I-SF4006 (3)
3.0 Well Implants	∅ 4.0	8.0 mm	I-SF4008 (3)
3.0 Well Implants	∅ 4.0	10 mm	I-SF4010 (3)
3.0 Well Implants	∅ 4.5	5.0 mm	I-SF4505 (3)
3.0 Well Implants	∅ 4.5	6.0 mm	I-SF4506 (3)
3.0 Well Implants	∅ 4.5	8.0 mm	I-SF4508 (3)
3.0 Well Implants	∅ 4.5	10 mm	I-SF4510 (3)
3.0 Well Implants	∅ 5.0	4.0 mm	I-SF5004 (3)
3.0 Well Implants	∅ 5.0	5.0 mm	I-SF5005 (3)
3.0 Well Implants	∅ 5.0	6.0 mm	I-SF5006 (3)
3.0 Well Implants	∅ 5.0	8.0 mm	I-SF5008 (3)
3.0 Well Implants	∅ 5.0	10 mm	I-SF5010 (3)
3.0 Well Implants	∅ 5.5	4.0 mm	I-SF5504 (3)
3.0 Well Implants	∅ 5.5	5.0 mm	I-SF5505 (3)
3.0 Well Implants	∅ 5.5	6.0 mm	I-SF5506 (3)
3.0 Well Implants	∅ 5.5	8.0 mm	I-SF5508 (3)
3.0 Well Implants	∅ 6.0	4.0 mm	I-SF6004 (3)
3.0 Well Implants	∅ 6.0	5.0 mm	I-SF6005 (3)
3.0 Well Implants	∅ 6.0	6.0 mm	I-SF6006 (3)
3.0 Well Implants	∅ 6.0	8.0 mm	I-SF6008 (3)



ABUTMENTS

PRODUCT	GH	WIDTH	HEIGHT	ANGLE	CODE
SHOULDERED ABUTMENTS					
2.0 POST					
2.0 Post Shouldered Abutment	1	ø 4.0	6.5 mm	0	I-SSA 1040 (2)
2.0 Post Shouldered Abutment	1	ø 5.0	6.5 mm	0	I-SSA 1050 (2)
2.0 Post Shouldered Abutment	2	ø 4.0	6.5 mm	0	I-SSA 2040 (2)
2.0 Post Shouldered Abutment	2	ø 5.0	6.5 mm	0	I-SSA 2050 (2)
2.0 Post Shouldered Angled Abutment	2	ø 4.0	6.5 mm	15°	I-SSAA 2040-15 (2)
2.0 Post Shouldered Angled Abutment	2	ø 5.0	6.5 mm	15°	I-SSAA 2050-15 (2)
2.0 Post Shouldered Angled Abutment	2	ø 4.0	6.5 mm	25°	I-SSAA 2040-25 (2)
2.0 Post Shouldered Angled Abutment	2	ø 5.0	6.5 mm	25°	I-SSAA 2050-25 (2)
2.0 Post Shouldered Abutment	3	ø 4.0	6.5 mm	0	I-SSA 3040 (2)
2.0 Post Shouldered Abutment	3	ø 5.0	6.5 mm	0	I-SSA 3050 (2)
2.0 Post Shouldered Abutment	4	ø 4.0	6.5 mm	0	I-SSA 4040 (2)
2.0 Post Shouldered Abutment	4	ø 5.0	6.5 mm	0	I-SSA 4050 (2)
2.0 Post Shouldered Angled Abutment	4	ø 4.0	6.5 mm	15°	I-SSAA 4040-15 (2)
2.0 Post Shouldered Angled Abutment	4	ø 5.0	6.5 mm	15°	I-SSAA 4050-15 (2)
2.0 Post Shouldered Angled Abutment	4	ø 4.0	6.5 mm	25°	I-SSAA 4040-25 (2)
2.0 Post Shouldered Angled Abutment	4	ø 5.0	6.5 mm	25°	I-SSAA 4050-25 (2)
2.0 Post Shouldered Abutment	5	ø 4.0	6.5 mm	0	I-SSA 5040 (2)
2.0 Post Shouldered Abutment	5	ø 5.0	6.5 mm	0	I-SSA 5050 (2)
2.0 Post Shouldered Abutment	6	ø 4.0	6.5 mm	0	I-SSA 6040 (2)
2.0 Post Shouldered Abutment	6	ø 5.0	6.5 mm	0	I-SSA 6050 (2)
2.0 Post Shouldered Angled Abutment	6	ø 4.0	6.5 mm	15°	I-SSAA 6040-15 (2)
2.0 Post Shouldered Angled Abutment	6	ø 5.0	6.5 mm	15°	I-SSAA 6050-15 (2)
2.0 Post Shouldered Angled Abutment	6	ø 4.0	6.5 mm	25°	I-SSAA 6040-25 (2)
2.0 Post Shouldered Angled Abutment	6	ø 5.0	6.5 mm	25°	I-SSAA 6050-25 (2)

ABUTMENTS

PRODUCT	GH	WIDTH	HEIGHT	ANGLE	CODE
SHOULDERED ABUTMENTS					
2.5 POST					
2.5 Post Shouldered Abutment	1	∅ 4.0	6.5 mm	0	I-SSA 1040 (2.5)
2.5 Post Shouldered Abutment	1	∅ 5.0	6.5 mm	0	I-SSA 1050 (2.5)
2.5 Post Shouldered Abutment	2	∅ 4.0	6.5 mm	0	I-SSA 2040 (2.5)
2.5 Post Shouldered Abutment	2	∅ 5.0	6.5 mm	0	I-SSA 2050 (2.5)
2.5 Post Shouldered Abutment	3	∅ 4.0	6.5 mm	0	I-SSA 3040 (2.5)
2.5 Post Shouldered Abutment	3	∅ 5.0	6.5 mm	0	I-SSA 3050 (2.5)
2.5 Post Shouldered Abutment	4	∅ 4.0	6.5 mm	0	I-SSA 4040 (2.5)
2.5 Post Shouldered Abutment	4	∅ 5.0	6.5 mm	0	I-SSA 4050 (2.5)
2.5 Post Shouldered Abutment	5	∅ 4.0	6.5 mm	0	I-SSA 5040 (2.5)
2.5 Post Shouldered Abutment	5	∅ 5.0	6.5 mm	0	I-SSA 5050 (2.5)
2.5 Post Shouldered Abutment	6	∅ 4.0	6.5 mm	0	I-SSA 6040 (2.5)
2.5 Post Shouldered Abutment	6	∅ 5.0	6.5 mm	0	I-SSA 6050 (2.5)



ABUTMENTS

PRODUCT	GH	WIDTH	HEIGHT	ANGLE	CODE
SHOULDERED ABUTMENTS					
3.0 POST					
3.0 Post Shouldered Abutment	1	∅ 5.0	6.5 mm	0	I-SSA 1050 (3)
3.0 Post Shouldered Abutment	1	∅ 6.5	6.5 mm	0	I-SSA 1065 (3)
3.0 Post Shouldered Abutment	2	∅ 5.0	6.5 mm	0	I-SSA 2050 (3)
3.0 Post Shouldered Abutment	2	∅ 6.5	6.5 mm	0	I-SSA 2065 (3)
3.0 Post Shouldered Angled Abutment	2	∅ 5.0	6.5 mm	15°	I-SSAA 2050-15 (3)
3.0 Post Shouldered Angled Abutment	2	∅ 6.5	6.5 mm	15°	I-SSAA 2065-15 (3)
3.0 Post Shouldered Angled Abutment	2	∅ 5.0	6.5 mm	25°	I-SSAA 2050-25 (3)
3.0 Post Shouldered Angled Abutment	2	∅ 6.5	6.5 mm	25°	I-SSAA 2065-25 (3)
3.0 Post Shouldered Abutment	3	∅ 5.0	6.5 mm	0	I-SSA 3050 (3)
2.0 Post Shouldered Abutment	3	∅ 6.5	6.5 mm	0	I-SSA 3065 (3)
3.0 Post Shouldered Abutment	4	∅ 5.0	6.5 mm	0	I-SSA 4050 (3)
3.0 Post Shouldered Abutment	4	∅ 6.5	6.5 mm	0	I-SSA 4065 (3)
3.0 Post Shouldered Angled Abutment	4	∅ 5.0	6.5 mm	15°	I-SSAA 4050-15 (3)
3.0 Post Shouldered Angled Abutment	4	∅ 6.5	6.5 mm	15°	I-SSAA 4065-15 (3)
3.0 Post Shouldered Angled Abutment	4	∅ 5.0	6.5 mm	25°	I-SSAA 4050-25 (3)
3.0 Post Shouldered Angled Abutment	4	∅ 6.5	6.5 mm	25°	I-SSAA 4065-25 (3)
3.0 Post Shouldered Abutment	5	∅ 5.0	6.5 mm	0	I-SSA 5050 (3)
3.0 Post Shouldered Abutment	5	∅ 6.6	6.5 mm	0	I-SSA 5065 (3)
3.0 Post Shouldered Abutment	6	∅ 5.0	6.5 mm	0	I-SSA 6050 (3)
3.0 Post Shouldered Abutment	6	∅ 6.5	6.5 mm	0	I-SSA 6065 (3)
3.0 Post Shouldered Angled Abutment	6	∅ 5.0	6.5 mm	15°	I-SSAA 6050-15 (3)
3.0 Post Shouldered Angled Abutment	6	∅ 6.5	6.5 mm	15°	I-SSAA 6065-15 (3)
3.0 Post Shouldered Angled Abutment	6	∅ 5.0	6.5 mm	25°	I-SSAA 6050-25 (3)
3.0 Post Shouldered Angled Abutment	6	∅ 6.5	6.5 mm	25°	I-SSAA 6065-25 (3)

ABUTMENTS

PRODUCT	GH	WIDTH	HEIGHT	ANGLE	CODE
NON - SHOULDERED ABUTMENTS					
2.0 POST					
2.0 Post Non-Shouldered Abutment	2	∅ 4.0	7.5 mm	0	I-SNSA 2040 (2)
2.0 Post Non-Shouldered Abutment	2	∅ 5.0	7.5 mm	0	I-SNSA 2050 (2)
2.0 Post Non-Shouldered Angled Abutment	2	∅ 4.0	7.5 mm	15°	I-SNSAA 2040-15 (2)
2.0 Post Non-Shouldered Angled Abutment	2	∅ 5.0	7.5 mm	15°	I-SNSAA 2050-15 (2)
2.0 Post Non-Shouldered Angled Abutment	2	∅ 4.0	7.5 mm	25°	I-SNSAA 2040-25 (2)
2.0 Post Non-Shouldered Angled Abutment	2	∅ 5.0	7.5 mm	25°	I-SNSAA 2050-25 (2)
2.0 Post Non-Shouldered Abutment	3	∅ 4.0	7.5 mm	0	I-SNSA 3040 (2)
2.0 Post Non-Shouldered Abutment	3	∅ 5.0	7.5 mm	0	I-SNSA 3050 (2)
2.0 Post Non-Shouldered Abutment	4	∅ 4.0	7.5 mm	0	I-SNSA 4040 (2)
2.0 Post Non-Shouldered Abutment	4	∅ 5.0	7.5 mm	0	I-SNSA 4050 (2)
2.0 Post Non-Shouldered Angled Abutment	4	∅ 4.0	7.5 mm	15°	I-SNSAA 4040-15 (2)
2.0 Post Non-Shouldered Angled Abutment	4	∅ 5.0	7.5 mm	15°	I-SNSAA 4050-15 (2)
2.0 Post Non-Shouldered Angled Abutment	4	∅ 4.0	7.5 mm	25°	I-SNSAA 4040-25 (2)
2.0 Post Non-Shouldered Angled Abutment	4	∅ 5.0	7.5 mm	25°	I-SNSAA 4050-25 (2)
2.0 Post Non-Shouldered Abutment	5	∅ 4.0	7.5 mm	0	I-SNSA 5040 (2)
2.0 Post Non-Shouldered Abutment	5	∅ 5.0	7.5 mm	0	I-SNSA 5050 (2)

PRODUCT	GH	WIDTH	HEIGHT	ANGLE	CODE
NON - SHOULDERED ABUTMENTS					
2.5 POST					
2.5 Post Non-Shouldered Abutment	3	∅ 4.0	7.5 mm	0	I-SNSA 3040 (2.5)
2.5 Post Non-Shouldered Abutment	3	∅ 5.0	7.5 mm	0	I-SNSA 3050 (2.5)
2.5 Post Non-Shouldered Abutment	4	∅ 4.0	7.5 mm	0	I-SNSA 4040 (2.5)
2.5 Post Non-Shouldered Abutment	4	∅ 5.0	7.5 mm	0	I-SNSA 4050 (2.5)
2.5 Post Non-Shouldered Angled Abutment	4	∅ 4.0	7.5 mm	15°	I-SNSAA 4040-15 (2.5)
2.5 Post Non-Shouldered Angled Abutment	4	∅ 5.0	7.5 mm	15°	I-SNSAA 4050-15 (2.5)
2.5 Post Non-Shouldered Angled Abutment	4	∅ 4.0	7.5 mm	25°	I-SNSAA 4040-25 (2.5)
2.5 Post Non-Shouldered Angled Abutment	4	∅ 5.0	7.5 mm	25°	I-SNSAA 4050-25 (2.5)
2.5 Post Non-Shouldered Abutment	5	∅ 4.0	7.5 mm	0	I-SNSA 5040 (2.5)
2.5 Post Non-Shouldered Abutment	5	∅ 5.0	7.5 mm	0	I-SNSA 5050 (2.5)



ABUTMENTS

PRODUCT	GH	WIDTH	HEIGHT	ANGLE	CODE
2.5 Post Non-Shouldered Abutment	6	∅ 4.0	7.5 mm	0	I-SNSA 6040 (2.5)
2.5 Post Non-Shouldered Abutment	6	∅ 5.0	7.5 mm	0	I-SNSA 6050 (2.5)
2.5 Post Non-Shouldered Angled Abutment	6	∅ 4.0	7.5 mm	15°	I-SNSAA 6040-15 (2.5)
2.5 Post Non-Shouldered Angled Abutment	6	∅ 5.0	7.5 mm	15°	I-SNSAA 6050-15 (2.5)
2.5 Post Non-Shouldered Angled Abutment	6	∅ 4.0	7.5 mm	25°	I-SNSAA 6040-25 (2.5)
2.5 Post Non-Shouldered Angled Abutment	6	∅ 5.0	7.5 mm	25°	I-SNSAA 6050-25 (2.5)

PRODUCT	GH	WIDTH	HEIGHT	ANGLE	CODE
---------	----	-------	--------	-------	------

NON - SHOULDERED ABUTMENTS

3.0 POST

3.0 Post Non-Shouldered Abutment	3	∅ 5.0	7.5 mm	0	I-SNSA 3050 (3)
2.0 Post Non-Shouldered Abutment	3	∅ 6.5	7.5 mm	0	I-SNSA 3065 (3)
3.0 Post Non-Shouldered Abutment	4	∅ 5.0	7.5 mm	0	I-SNSA 4050 (3)
3.0 Post Non-Shouldered Abutment	4	∅ 6.5	7.5 mm	0	I-SNSA 4065 (3)
3.0 Post Non-Shouldered Angled Abutment	4	∅ 5.0	7.5 mm	15°	I-SNSAA 4050-15 (3)
3.0 Post Non-Shouldered Angled Abutment	4	∅ 6.5	7.5 mm	15°	I-SNSAA 4065-15 (3)
3.0 Post Non-Shouldered Angled Abutment	4	∅ 5.0	7.5 mm	25°	I-SNSAA 4050-25 (3)
3.0 Post Non-Shouldered Angled Abutment	4	∅ 6.5	7.5 mm	25°	I-SNSAA 4065-25 (3)
3.0 Post Non-Shouldered Abutment	5	∅ 5.0	7.5 mm	0	I-SNSA 5050 (3)
3.0 Post Non-Shouldered Abutment	5	∅ 6.6	7.5 mm	0	I-SNSA 5065 (3)

LOCATOR ABUTMENTS

PRODUCT	GH	WIDTH	CODE
---------	----	-------	------

2.0 POST

2.0 Post Locator Abutment	2	∅ 3.86	I-SLA 20 (2)
2.0 Post Locator Abutment	4	∅ 3.86	I-SLA 40 (2)
2.0 Post Locator Abutment	6	∅ 3.86	I-SLA 60 (2)

2.5 POST

2.5 Post Locator Abutment	2	∅ 3.86	I-SLA 20 (2.5)
2.5 Post Locator Abutment	4	∅ 3.86	I-SLA 40 (2.5)
2.5 Post Locator Abutment	6	∅ 3.86	I-SLA 60 (2.5)

3.0 POST

3.0 Post Locator Abutment	2	∅ 3.86	I-SLA 20 (3)
3.0 Post Locator Abutment	4	∅ 3.86	I-SLA 40 (3)
3.0 Post Locator Abutment	6	∅ 3.86	I-SLA 60 (3)

BALL ABUTMENTS

PRODUCT	GH	WIDTH	CODE
2.0 POST			
2.0 Post Ball Abutment	1	∅ 5	I-SBA 10 (2)
2.0 Post Ball Abutment	2	∅ 5	I-SBA 20 (2)
2.0 Post Ball Abutment	3	∅ 5	I-SBA 30 (2)
2.0 Post Ball Abutment	4	∅ 5	I-SBA 40 (2)
2.0 Post Ball Abutment	5	∅ 5	I-SBA 50 (2)
2.0 Post Ball Abutment	6	∅ 5	I-SBA 60 (2)
2.5 POST			
2.5 Post Ball Abutment	1	∅ 5	I-SBA 10 (2.5)
2.5 Post Ball Abutment	2	∅ 5	I-SBA 20 (2.5)
2.5 Post Ball Abutment	3	∅ 5	I-SBA 30 (2.5)
2.5 Post Ball Abutment	4	∅ 5	I-SBA 40 (2.5)
2.5 Post Ball Abutment	5	∅ 5	I-SBA 50 (2.5)
2.5 Post Ball Abutment	6	∅ 5	I-SBA 60 (2.5)
3.0 POST			
3.0 Post Ball Abutment	1	∅ 5	I-SBA 10 (3)
3.0 Post Ball Abutment	2	∅ 5	I-SBA 20 (3)
3.0 Post Ball Abutment	3	∅ 5	I-SBA 30 (3)
3.0 Post Ball Abutment	4	∅ 5	I-SBA 40 (3)
3.0 Post Ball Abutment	5	∅ 5	I-SBA 50 (3)
3.0 Post Ball Abutment	6	∅ 5	I-SBA 60 (3)

HEALING ABUTMENTS

PRODUCT	GH	WIDTH	CODE
2.0 POST			
2.0 Post Healing Abutment	4	∅ 4.0	I-SHA 4040 (2)
2.0 Post Healing Abutment	4	∅ 5.0	I-SHA 4050 (2)
2.0 Post Healing Abutment	6	∅ 4.0	I-SHA 6040 (2)
2.0 Post Healing Abutment	6	∅ 5.0	I-SHA 6050 (2)
2.5 POST			
2.5 Post Healing Abutment	4	∅ 4.0	I-SHA 4040 (2.5)
2.5 Post Healing Abutment	4	∅ 5.0	I-SHA 4050 (2.5)
2.5 Post Healing Abutment	6	∅ 4.0	I-SHA 6040 (2.5)
2.5 Post Healing Abutment	6	∅ 5.0	I-SHA 6050 (2.5)
3.0 POST			
3.0 Post Healing Abutment	4	∅ 5.0	I-SHA 4050 (3)
3.0 Post Healing Abutment	4	∅ 6.5	I-SHA 4065 (3)
3.0 Post Healing Abutment	6	∅ 5.0	I-SHA 6050 (3)
3.0 Post Healing Abutment	6	∅ 6.5	I-SHA 6065 (3)



SINUS ABUTMENTS

PRODUCT	WIDTH	HEIGHT	CODE
3.0 POST			
3.0 Post Sinus Abutment	∅ 6.5	5.0 mm	I-SSINA 5065 (3)
3.0 Post Sinus Abutment	∅ 7.5	6.0 mm	I-SSINA 6075 (3)

TI-BASE ABUTMENTS

PRODUCT	GH	WIDTH	HEIGHT	CODE
2.0 POST				
2.0 Post Ti-Base Abutment	1	∅ 4.5	4.5 mm	I-STIA 1045 (2)
2.0 Post Ti-Base Abutment	2	∅ 4.5	4.5 mm	I-STIA 2045 (2)
2.0 Post Ti-Base Abutment	3	∅ 4.5	4.5 mm	I-STIA 3045 (2)
2.5 POST				
2.5 Post Ti-Base Abutment	1	∅ 4.5	4.5 mm	I-STIA 1045 (2.5)
2.5 Post Ti-Base Abutment	2	∅ 4.5	4.5 mm	I-STIA 2045 (2.5)
2.5 Post Ti-Base Abutment	3	∅ 4.5	4.5 mm	I-STIA 3045 (2.5)
3.0 POST				
3.0 Post Ti-Base Abutment	1	∅ 4.5	4.5 mm	I-STIA 1045 (3)
3.0 Post Ti-Base Abutment	2	∅ 4.5	4.5 mm	I-STIA 2045 (3)
3.0 Post Ti-Base Abutment	3	∅ 4.5	4.5 mm	I-STIA 3045 (3)

MULTI-UNIT ABUTMENTS

PRODUCT	GH	WIDTH	CODE
2.0 POST			
2.0 Post Multi-Unit Abutment	1	∅ 5	I-SMUA 1050 (2)
2.0 Post Multi-Unit Abutment	2	∅ 5	I-SMUA 2050 (2)
2.0 Post Multi-Unit Abutment	3	∅ 5	I-SMUA 3050 (2)
2.0 Post Multi-Unit Abutment	5	∅ 5	I-SMUA 5050 (2)
2.5 POST			
2.5 Post Multi-Unit Abutment	1	∅ 5	I-SMUA 1050 (2.5)
2.5 Post Multi-Unit Abutment	2	∅ 5	I-SMUA 2050 (2.5)
2.5 Post Multi-Unit Abutment	3	∅ 5	I-SMUA 3050 (2.5)
2.5 Post Multi-Unit Abutment	5	∅ 5	I-SMUA 5050 (2.5)
3.0 POST			
3.0 Post Multi-Unit Abutment	1	∅ 5	I-SMUA 1050 (3)
3.0 Post Multi-Unit Abutment	2	∅ 5	I-SMUA 2050 (3)
3.0 Post Multi-Unit Abutment	3	∅ 5	I-SMUA 3050 (3)
3.0 Post Multi-Unit Abutment	5	∅ 5	I-SMUA 5050 (3)

MULTI-UNIT ANGLE ABUTMENTS

PRODUCT	GH	WIDTH	ANGLE	CODE
2.0 POST				
2.0 Post Multi-Unit Angle Abutment	3	∅ 5	17°	I-SMUA 3050-17 (2)
2.0 Post Multi-Unit Angle Abutment	3	∅ 5	33°	I-SMUA 3050-33 (2)
2.0 Post Multi-Unit Angle Abutment	5	∅ 5	17°	I-SMUA 5050-17 (2)
2.0 Post Multi-Unit Angle Abutment	5	∅ 5	33°	I-SMUA 5050-33 (2)
3.0 POST				
3.0 Post Multi-Unit Angle Abutment	3	∅ 5	17°	I-SMUA 3050-17 (3)
3.0 Post Multi-Unit Angle Abutment	3	∅ 5	33°	I-SMUA 3050-33 (3)
3.0 Post Multi-Unit Angle Abutment	5	∅ 5	17°	I-SMUA 5050-17 (3)
3.0 Post Multi-Unit Angle Abutment	5	∅ 5	33°	I-SMUA 5050-33 (3)

IMPRESSION COMPONENTS - ANALOG

PRODUCT	CODE
IMPRESSION POSTS	
2.0 Post Impression Post	I-SIP (2)
2.5 Post Impression Post	I-SIP (2.5)
3.0 Post Impression Post	I-SIP (3)
2.0 Post Impression Post with Cap	I-SIPc (2)
2.5 Post Impression Post with Cap	I-SIPc (2.5)
3.0 Post Impression Post with Cap	I-SIPc (3)
FIXTURE ANALOGS	
2.0 Post Fixture Analogs	I-SFA (2)
2.5 Post Fixture Analogs	I-SFA (2.5)
3.0 Post Fixture Analogs	I-SFA (3)
MULTI UNIT BURN OUT CYLINDER	
Multi Unit Burn Out Cylinder	I-SMUAPICYN
MULTI UNIT ABUTMENT IMPRESSION COPING PICK-UP	
Multi Unit Abutment Impression Coping Pick-up	I-SMUAIP
MULTI UNIT ABUTMENT ANALOG	
Multi Unit Abutment Analog	I-SMUALA
MULTI UNIT ABUTMENT HEALING CAP	
Multi Unit Abutment Healing Cap	I-SMUAHCap



PRODUCT	WIDTH	HEIGHT	CODE
SHOULDERED ABUTMENT LEVEL IMPRESSION CAP			
Shouldered Abutment Level Impression Cap	∅ 4.0	6.5 mm	I-SSAS 4065
Shouldered Abutment Level Impression Cap	∅ 5.0	6.5 mm	I-SSAS 5065
Shouldered Abutment Level Impression Cap	∅ 6.5	6.5 mm	I-SSAS 6565
SHOULDERED ABUTMENT ANALOG			
Shouldered Abutment Analog	∅ 4.0	6.5 mm	I-SSAA 4065
Shouldered Abutment Analog	∅ 5.0	6.5 mm	I-SSAA 5065
Shouldered Abutment Analog	∅ 6.5	6.5 mm	I-SSAA 6565

PRODUCT	CODE
LOCATOR ABUTMENT RETAINER	
Locator Abutment Retainer	I-SLAR
LOCATOR ABUTMENT ANALOG	
Locator Abutment Analog	I-SLAA
BALL ABUTMENT ABUTMENT RETAINER	
Ball Abutment Retainer	I-SRAR
BALL ABUTMENT ABUTMENT ANALOG	
Ball Abutment Analog	I-SRAA

DIGITAL SOLUTIONS

PRODUCT	WIDTH	CODE
PREMILLS		
2.0 Post Premill	10 mm	I-SPA10 (2)
2.0 Post Premill	14 mm	I-SPA14 (2)
2.0 Post Premill	16 mm	I-SPA16 (2)
2.5 Post Premill	10 mm	I-SPA10 (2.5)
2.5 Post Premill	14 mm	I-SPA14 (2.5)
2.5 Post Premill	16 mm	I-SPA16 (2.5)
3.0 Post Premill	10 mm	I-SPA10 (3)
3.0 Post Premill	14 mm	I-SPA14 (3)
3.0 Post Premill	16 mm	I-SPA16 (3)
LAB ANALOG		
2.0 Post Lab Analog		I-SDLab (2)
2.5 Post Lab Analog		I-SDLab (2.5)
3.0 Post Lab Analog		I-SDLab (3)
SCAN BODY		
2.0 Post Scan Body		I-PSB (2)
2.5 Post Scan Body		I-PSB (2.5)
3.0 Post Scan Body		I-PSB (3)

SURGICAL PROTOCOL

PRODUCT	CODE
GUIDE PIN	
2.0 Well Guide Pin	I-SGP-20
2.5 Well Guide Pin	I-SGP-25
3.0 Well Guide Pin	I-SGP-30
PARALELLING PINS	
Straight Paralelling Pin	I-SPP-0
Angled Paralelling Pin (15°)	I-SPP-15

PRODUCT	WIDTH	CODE
OSTEOTOMES		
Osteotomes	3.5 mm	I-SOST-35
Osteotomes	4.0 mm	I-SOST-40
Osteotomes	4.5 mm	I-SOST-45
Osteotomes	5.0 mm	I-SOST-50
Osteotomes	6.0 mm	I-SOST-60
PILOT DRILLS \varnothing 2.0 mm		
Pilot Drills	5.0 mm	I-SPD-05
Pilot Drills	6.0 mm	I-SPD-06
Pilot Drills	8.0 mm	I-SPD-08
Pilot Drills	10 mm	I-SPD-10
Pilot Drills	12 mm	I-SPD-12
PROFILE REAMERS		
Profile Reamer	4.0 mm	I-SSR-40
Profile Reamer	5.0 mm	I-SSR-50
Profile Reamer	6.5 mm	I-SSR-65
i-REAMERS		
i-Reamers	2.5 mm	I-SIR-25
i-Reamers	3.0 mm	I-SIR-30
i-Reamers	3.5 mm	I-SIR-35
i-Reamers	4.0 mm	I-SIR-40
i-Reamers	4.5 mm	I-SIR-45
i-Reamers	5.0 mm	I-SIR-50
i-Reamers	5.5 mm	I-SIR-55
i-Reamers	6.0 mm	I-SIR-60
L-REAMERS		
L-Reamers	2.5 mm	I-SIRL-25
L-Reamers	3.0 mm	I-SIRL-30
L-Reamers	3.5 mm	I-SIRL-35
L-Reamers	4.0 mm	I-SIRL-40
L-Reamers	4.5 mm	I-SIRL-45
L-Reamers	5.0 mm	I-SIRL-50
L-Reamers	5.5 mm	I-SIRL-55
L-Reamers	6.0 mm	I-SIRL-60



PRODUCT	CODE
STRAIGHT HANDLE Straight Handle	I-SSH
CURVED HANDLE Curved Handle	I-SCH
KNOB Knob	I-SKNB
DRILL EXTENSION Drill Extension	I-SDE
PLUG REMOVER Plug Remover Short Plug Remover Long	I-SPRS I-SPR
ABUTMENT TIP Abutment Tip	I-SAT
SEATING TIP 2.0 Well Seating Tip 2.5 Well Seating Tip 3.0 Well Seating Tip	I-SST-20 I-SST-25 I-SST-30
UNIVERSAL INSERTER - RETRIEVER Universal Inserter - Retriever	I-SUIR
DENTAL HAMMER Dental Hammer	I-SHMR
ABUTMENT HANDLE Abutment Handle	I-SAH
DENTAL SCISSOR Dental Scissor	I-SCS
FORCEPS Maxillary Extraction Forceps Mandibulary Extraction Forceps	I-SFRCL I-SFRCU





Novodent SA

Y-Parc Technopole
Avenue des Sciences 11
CH-1400, Yverdon-les-Bains
Switzerland